

PowerSet®

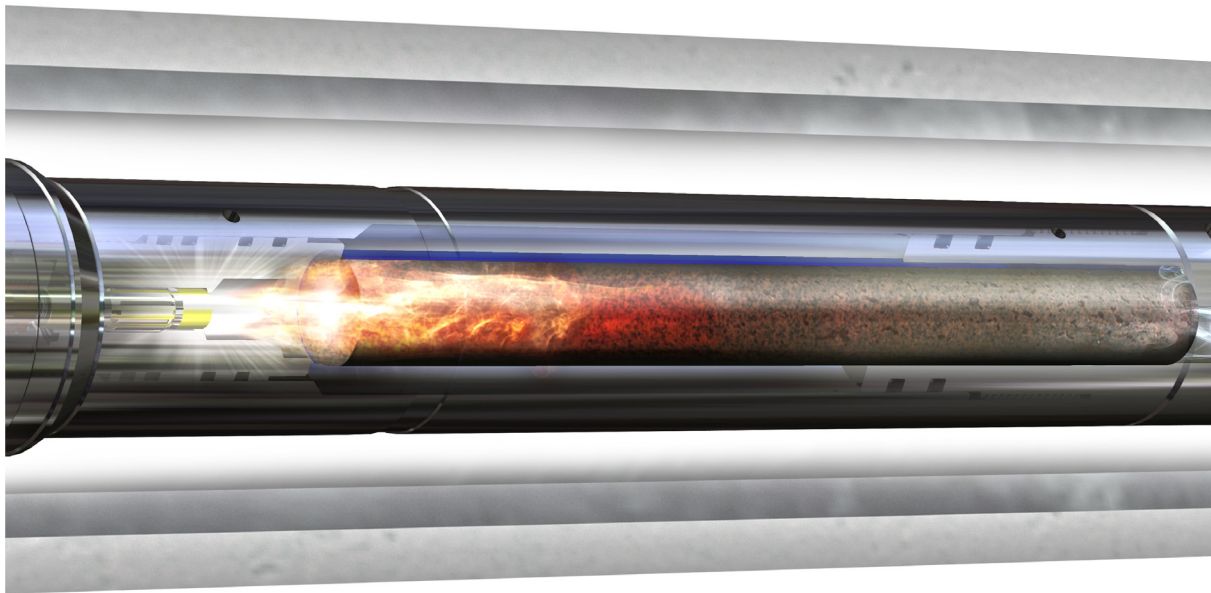

PowerSet Power Charges,
Compatible Setting Tools, Hardware

PowerSet®

www.hunting-intl.com/titan

Hunting's PowerSet® power charges are the optimal choice for use with the T-Set® family of setting tools.

Benefits ▶

- Optimal, consistent setting times at temperature
- Compatible with existing igniters
- No secondary igniter required
- Capable of setting tool applications up to 55,000 lbs shear

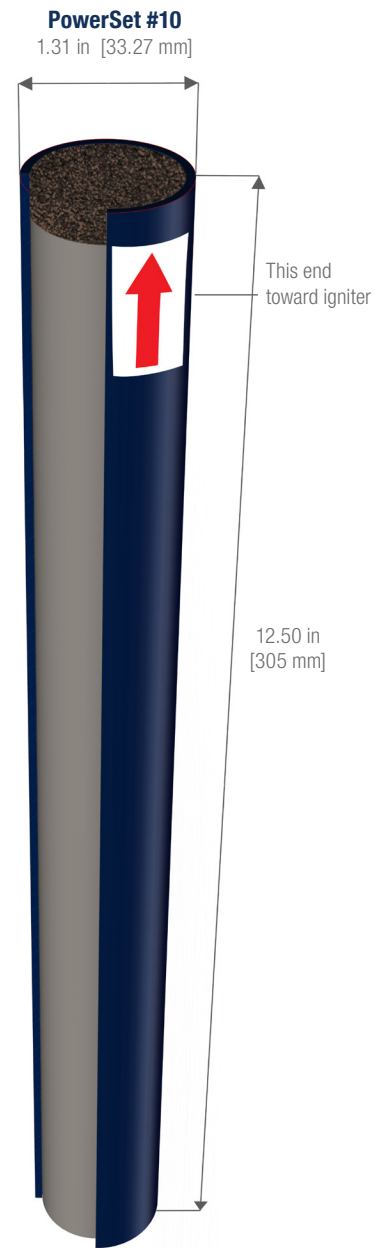

PowerSet Charge Specifications

Specifications	PowerSet #10F (Fast Burn)	PowerSet #10	PowerSet #20	PowerSet 3-1/2 in.	PowerSet 3-5/8 in.
Part Number	HPC-0010-412	HPC-0010-411	HPC-0020-511	HPC-3500-711	HPC-3625-511
Outside Diameter (in) [mm]	1.31 [33.27]	1.31 [33.27]	1.62 [41.15]	2.13 [54.10]	1.31 [33.27]
Length (in) [mm]	12.50 [318]	12.50 [318]	12.00 [305]	9.00 [229]	14.50 [368]
Max. 1 Hour Temp. Rating (°F) [°C]	400 [204]	400 [204]	400 [204]	400 [204]	400 [204]
Explosive Weight (kg)	0.4 Kg	0.4 Kg	0.5 Kg	0.7 Kg	0.4 Kg
Hazard Class	1.4C	1.4C	1.4C	1.4C	1.4C
UN Number	0278	0278	0278	0278	0278
DOT Number	EX2016020060	EX2016020060	EX2016020060	EX2016020060	EX2016020060

PowerSet Hardware

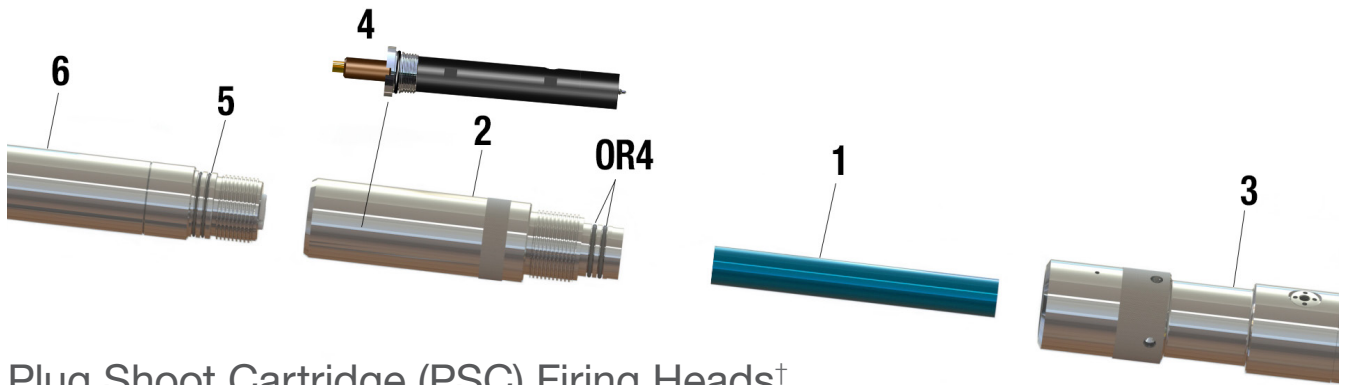

Plug Shoot Cartridge (PSC) Firing Heads[†]

ID	Description	Part Number
1	Powerset #10F Power Charge (Fast Burn)	HPC-0010-412
	PowerSet #10 Power Charge	HPC-0010-411
	PowerSet #20 Power Charge	HPC-0020-511
2	3-1/8" PowerSet #10 PSC Firing Head	2010-312-200
	3-1/8" PowerSet #20 PSC Firing Head	2020-312-200
3	T-Set [®] Setting Tool	See T-Set Setting Tool Compatibility Table
4	Plug Shoot Cartridge (Psc)	HTS-PSC-000
5	3-1/8" Esub Tandem Assy.	0363-ESUB-040B
	3-1/8" EB Tandem Assy.	0363-000-389A
6	Gun Assy; 6 Spf / 60° Phase	GUN
OR4	O-Ring; Nitrile (for #10)*	0111-222-090
	O-Ring; Nitrile (for #20)*	0111-328-090

Note: part numbers displayed are 3-1/8" O.D. for reference. 2-3/4" and 3-3/8" hardware is also available. | Viton O-Rings required in applications above 325°F.*

Conventional Style Firing Heads and Igniters[†]

Setting Tool Size (in.)/[mm]	Assembly Part Number	Contact Kit Part Number	Igniter Type	Igniter Part Numbers	Upper Head Connection
No. 10	2010-000-000	2010-000-002	BP Style	BOT-H437440001	1-3/16 in.-12 GO Box
	2010-000-020	2010-000-022	BP Style	BOT-H437440001	3-1/8 in. O.D. GO Quick-Change Assembly
	2010-000-040	2010-000-022	BP Style	BOT-H437440001	2-3/4 in. O.D. GO Quick-Change Assembly
	2010-000-070	2010-000-072	BP Style	BOT-H437440001	3-1/8 in. O.D. SIE Quick-Change Assembly
	2010-000-100	-	GO	DET-2700-0742-DB	3-1/8 in. O.D. GO Quick-Change Assembly
	2010-000-111	-	GO	DET-2700-0742-DB	3-1/8 in. O.D. SIE Quick-Change Assembly
No. 20	2020-000-000	2020-000-002	BP Style	BOT-H437440001	1-3/16 in.-12 GO Box
	2020-000-020	2020-000-022	BP Style	BOT-H437440001	3-1/8 in. O.D. GO Quick-Change Assembly
	2020-000-070	2020-000-072	BP Style	BOT-H437440001	3-1/8 in. O.D. SIE Quick-Change Assembly
	2020-000-100	-	GO	DET-2700-0742-DB	3-1/8 in. O.D. GO Quick-Change Assembly
	2020-000-111	-	GO	DET-2700-0742-DB	3-1/8 in. O.D. SIE Quick-Change Assembly
3-1/2	WST-5321-132	-	GO	DET-2700-0742-DB	Adapter from #10 FH Box to 3-1/2" T-Set
	WST-5321-232	-	GO	DET-2700-0742-DB	Adapter from #20 FH Box to 3-1/2" T-Set
3-5/8	WST-3625-132	-	GO	DET-2700-0742-DB	Adapter from #10 FH Box to 3-5/8" T-Set
	WST-3625-133	-	GO	DET-2700-0742-DB	Adapter from #20 FH Box to 3-5/8" T-Set

Firing Heads, hardware, and o-rings are sold separately.†

Note: Viton O-rings need to be used above 325°F (163°C) | See T-Set Brochure for various firing head to T-Set adapters | For a full listing of sizes, compatibilities, and hardware, refer to manual.

PowerSet Power Charge Setting Times

POWERSET SIZE	SETTING FORCE*	75°F [24°C]	180°F [82°C]	250°F [121°C]
#10F (Fast Burn)	25,000 LBS	5 - 15 s	5 - 15 s	0 - 10 s
	35,000 LBS	5 - 20 s	5 - 20 s	0 - 10 s
#10	25,000 LBS	30 - 50 s	20 - 40 s	10 - 25 s
	35,000 LBS	35 - 55 s	25 - 45 s	10 - 30 s
	35,000 LBS	25 - 50 s	15 - 30 s	10 - 20 s
#20	45,000 LBS	30 - 60 s	15 - 30 s	10 - 20 s
	55,000 LBS	30 - 65 s	15 - 30 s	10 - 20 s
	45,000 LBS	25 - 40 s	15 - 30 s	0 - 20 s
3-1/2 in.	45,000 LBS	10 - 20 s	5 - 15 s	0 - 10 s
3-5/8 in.	45,000 LBS	10 - 20 s	5 - 15 s	0 - 10 s
	55,000 LBS	10 - 20 s	5 - 15 s	0 - 10 s

*All PowerSet Recons are rated for use up to 55,000 lbs shear

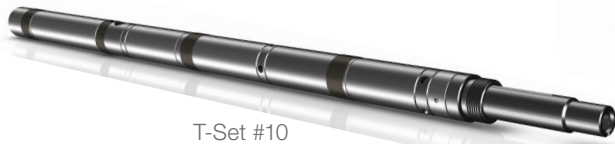

T-Set #10



T-Set One

T-Set Setting Tool Compatibility

COMPATIBLE T-SET SETTING TOOLS	POWERSET #10F HPC-0010-412	POWERSET #10 HPC-0010-411	POWERSET #20 HPC-0020-511	POWERSET 3-1/2 in. HPC-3500-711	POWERSET 3-5/8 in. HPC-3625-511
T-SET ONE SETTING TOOL TSET-ONE-000	✓				
T-SET #10 SETTING TOOL WST-BK10-001	✓	✓			
T-SET #20 SETTING TOOL WST-BK20-001			✓		
T-SET 3-1/2" SETTING TOOL WST-5321-110				✓	
T-SET 3-5/8" SETTING TOOL WST-3625-110					✓

Further Information

Web

www.hunting-intl.com

Email

sales.titan@hunting-intl.com

support.titan@hunting-intl.com

v2020.09.28

Global Headquarters

Hunting Energy Services Inc.

16825 Northchase Drive, Suite 600

Houston, Texas 77060-3236

USA

T. +1 281 442 7382



'Excellence in Energy Services for over 100 years'