

Pressure Control Equipment Product Catalogue



HUNTING

Introduction to PCE

PCE Configurator Web Application

PCE Product Range

Quick Union Reference





Pressure Control Equipment Product Catalogue

About Hunting	03
Introduction to Pressure Control Equipment	04
PCE Configurator Web Application	07
Ezi-Shear Seal Valve & Ezi-Shear Seal Valve - Heavy Duty	08

Pressure Control Equipment Product Range 12

Wireline Valves	12	Coiled Tubing PCE	42
Hunting Wireline Valves	13	ESSV-HD	43
EziClose® Hydraulic Cylinders	14	Coiled Tubing BOP	44
Wireline Valve Equalising Manifolds	15	Coiled Tubing In-Situ Pressure Test Sub	45
Work / Protection Frames	16	Coiled Tubing Stripper	46
Shipping Frames	17		
Wireline Valve Rams	18	Ezi-Latch	48
		Ezi-Latch (Hydraulic Wellhead Connector)	49
Stuffing Boxes	20	Stand-Alone Products	50
Hydraulic Slickline Stuffing Box	21	Hydraulic Line Wipers	51
EziLoad® Slickline Stuffing Box	22	Hydraulic Pack Off	52
Liquid Seal Head	24	Turnaround Sheave	53
15K EziLoad® Liquid Seal	25	PCH Stripper - Type 2	54
		PCH Stripper - Type 3	55
Tool Catchers	26	In-Situ Pressure Test Sub	56
Hunting EziCatch® Tool Catcher	27	Pump-In Sub	57
EziCombo Tool Catcher / Stuffing Box	28	Ball Valves	58
Open Hole Tool Catcher	29	Hay Pulleys / Sheaves	59
		Quick Union Rig Up Dolly	60
Grease Heads	30	Adapters	62
Cleanline Grease Inj. Control Head	31	Crossover Adapters	63
Cleanline Grease Inj. Control Head (DLW)	32		
Hydraulic Grease Head Cable Cutter	33	Ancillary Items	64
Chemical Injection / Inhibitor Sub	34	Quick Union Test Equipment	65
		Quick Union Lift / Test Cap	66
Lubricators and Risers	36	Quick Union Lifting Cap	67
Lubricators and Riser Sections	37		
Lifting Clamps, Spreader Bars and Slings	38	Quick Union Reference Table	68
Tool Traps	40		
Hydraulic Tool Trap	41		

Excellence in **Energy Services** for over 100 years

web. www.huntingplc.com

Well Intervention | Global Headquarters

Americas

1018 Rankin Road
Houston
Texas 77073 - 4606
USA

T. +1 281 821 5577
F. +1 281 821 6633

well.intervention.usa@hunting-intl.com

Europe / Russia / Africa

Badentoy Avenue
Badentoy Industrial Park
Portlethen, Aberdeen
United Kingdom

T. +44 1224 787000
F. +44 1224 787100

well.intervention@hunting-intl.com

Middle East

Building 23
Oilfield Supply Center
Jebel Ali, P.O. Box 261929
Dubai, UAE

T. +971 4 887 6850
F. +971 4 887 6849

well.intervention.mena@hunting-intl.com

Asia Pacific

22 Pioneer Crescent
#05 - 07 West Park Biz Central
Singapore 628 556
Singapore

T. +65 6863 0668
F. +65 6863 9196

well.intervention.asia@hunting-intl.com



About Hunting

Hunting provides products and services to the world's leading national, international energy companies and oil service companies enabling the extraction of oil and gas.

Manufacturing and sales locations are located in the key energy producing regions of the world.

Global Business Divisions

- OCTG and Connection Technology
- Drilling Tools
- Perforating Systems
- Intervention Tools
- Advanced Manufacturing
- Subsea

Proprietary Technology

Hunting owns and develops proprietary patented products with a full range of applications below the wellhead including mud motors, premium connections, well perforating, logging and intervention tools.

Geographic Footprint

In strategic locations around the world Hunting owns and operates plants, properties and equipment, employing people to serve its global customers with local services and products.

Hunting is committed to working safely in an environmentally responsible manner. These principles are fully integrated within our QMS that defines the company's global operations.

Quality Assurance

It is essential that products and services provided by Hunting are designed and manufactured to conform to the agreed API, proprietary licensor, or other specification of the customer, meeting their needs and expectations the first time, every time.

It is the policy of Hunting that only the highest quality products and services, that meet all specification requirements, are provided to customers. Hunting operates a corporate Quality Management System covering all worldwide locations.

Health, Safety and Environment

Hunting is committed to achieving and maintaining the highest standards of safety for its employees, customers, suppliers and the public. All Hunting business units consciously operate in a manner that includes environmental matters as an integral part of its business plan.

Hunting's aims are no accidents, no harm to people, and no damage to the environment. The Hunting goal is "Total Customer Satisfaction".

Introduction to Pressure Control Equipment

Hunting designs, manufactures and supports surface Pressure Control Equipment to allow clients to perform successful and safe well interventions in the most arduous conditions.

Equipment is manufactured to the most stringent quality standards comprising a comprehensive range including specialised packages to greatly reduce manual handling and enhance the safety of any intervention operation.



Pressure Control Equipment

Hunting's extensive product portfolio includes wireline valves, stuffing boxes, grease heads, lubricators and tool catchers.

Hunting's dedicated and experienced well intervention division is committed to improving well productivity and safety. Our success has been built around knowledge of the industry, correct planning, reliability of equipment and ability to react to client requirements through timely engineering service and teamwork.

Product and Service Offering

With a proactive approach to the ever increasing market demand for well engineered solutions for on and offshore operations, Hunting does not merely provide tools for sale but also on a rental basis offering design, build, testing and maintenance capabilities.

- In-House Specialist Engineers
- Purpose Built Facilities
- Highly Experienced Technicians
- Various Recertification including Annual and Major
- Pressure Testing
- Hydraulic Flushing
- Flying Squad
- Water Blasting
- Painting Services
- Portable Pressure Test Container



With manufacturing, sales and distribution centres strategically located in all major oil and gas regions of activity. Hunting is able to offer pressure control equipment from stock to support client activity.

Hunting continues to invest in the latest workshop technologies to ensure that a high quality level of service is maintained, including purpose built facilities and highly experienced technicians.

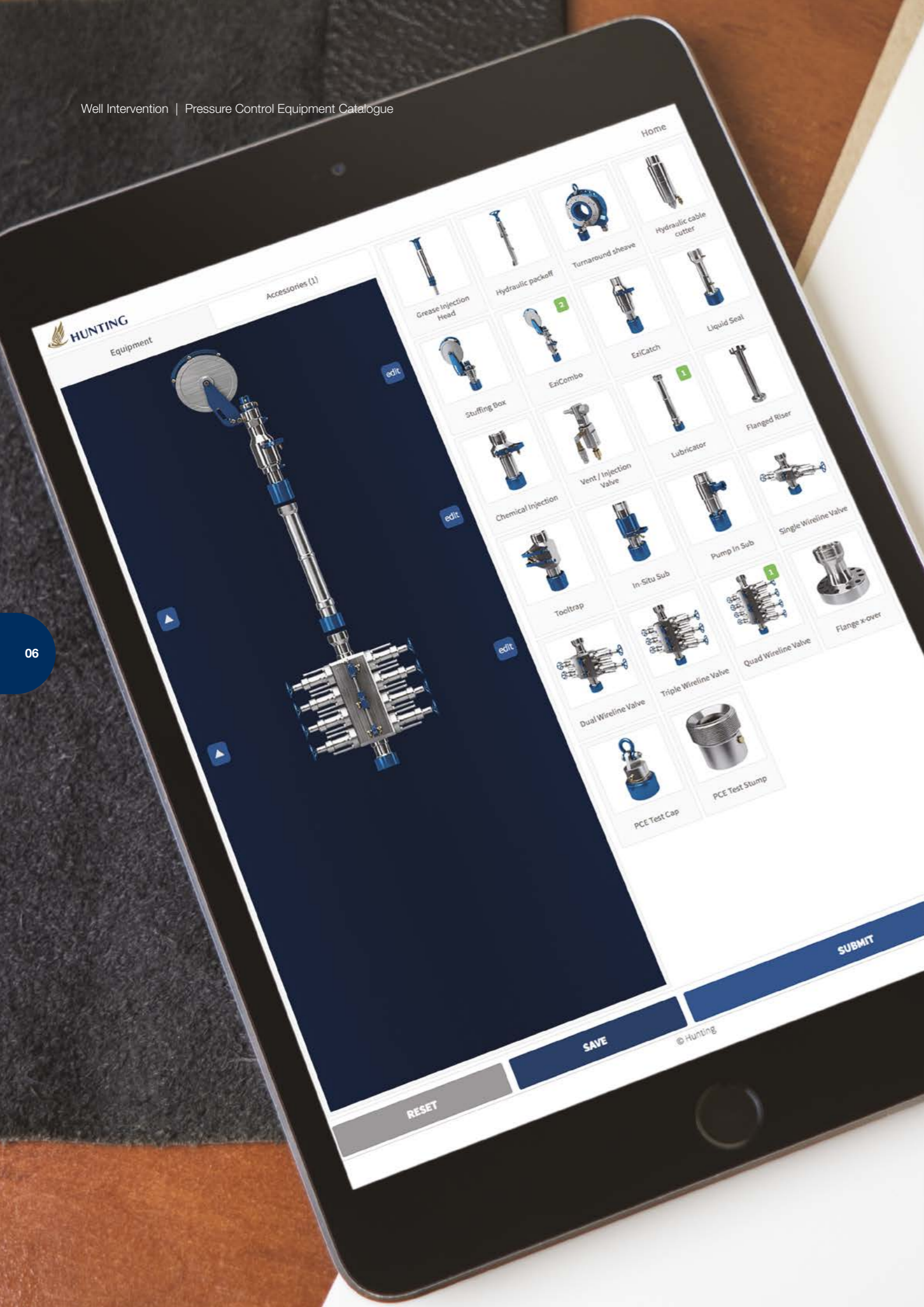

PCE Configurator Web Application

www.hunting-intl.com/well-intervention-equipment

PCE Configurator is a web based application that allows users to build an equipment package which can be submitted directly to the Well Intervention sales team.

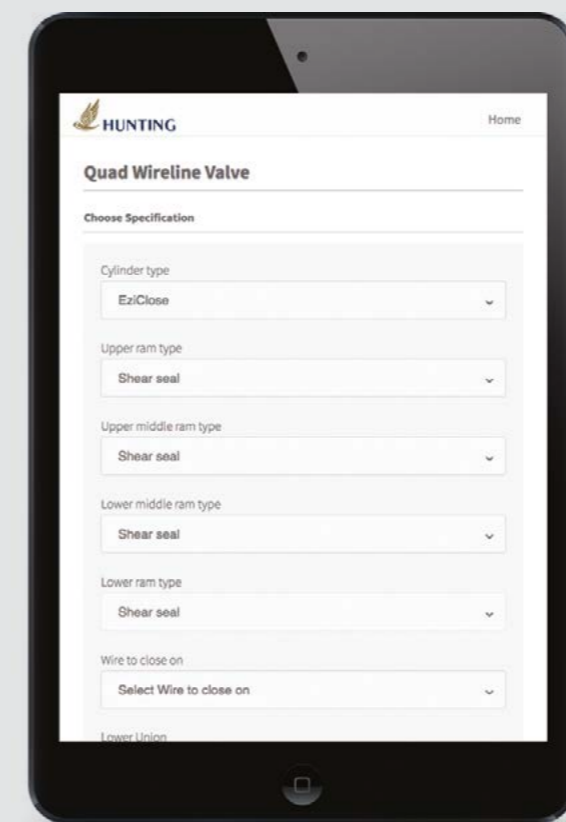
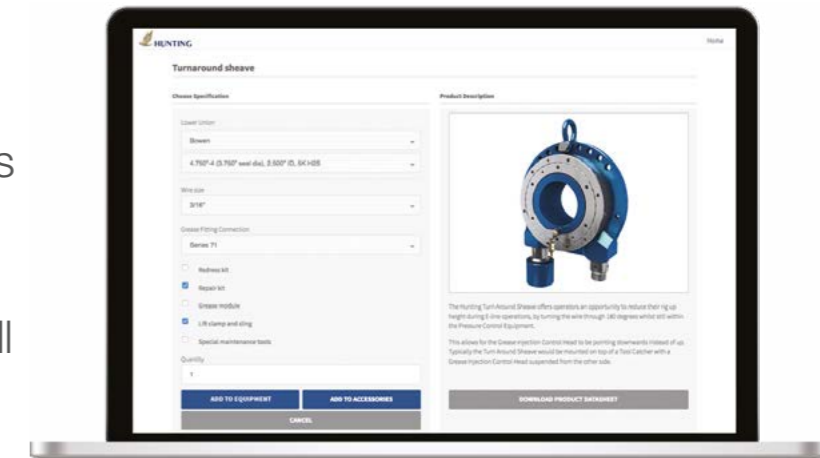

PCE Configurator allows customers to select components from a pictorial list and select union type and size, wire size as well as additional accessories such as spares and redress kits.

Once submitted, one of the well intervention technical sales engineers will be in touch to discuss your requirements.

Work on the Go

Create and save your pressure control equipment requirements at the rig site, at home or in the office using mobile or tablet devices.

Custom Specification

Choose from a comprehensive specification list - select a union type and size, wire size, repair and redress kits.

Add Accessories

Select and add additional products as accessories to your order such as spares and alternative sizes.

Liaise Direct with Sales Team

After submitting your toolstring, our well intervention sales team will contact you directly to discuss and finalise your order.

Ezi-Shear Seal Valve & Ezi-Shear Seal Valve - Heavy Duty

Hunting revolutionized well intervention operations with the original shear and seal valve and now offers the heavy duty valve to compliment the product family, offering an expanded range delivering safety, reliability and well integrity for Slickline, Braided Line, E-Line or Coiled Tubing operations.



1 Ezi-Shear Seal Valve

2 Ezi-Shear Seal Valve - Heavy Duty

Features

- Wide range of cutting capabilities
- Independent shearing and seal faces
- Compact design, smaller than traditional shear and seal valves
- Dual rotational hydraulic actuators
- Monoblock body
- Highly resistant to wear

Benefits

- Cuts Slickline, Braided and E-line (ESSV)
- Cuts Slickline, Braided, E-line and Coiled Tubing (ESSV-HD)
- Improved safety and reliability
- Reduced leak paths
- Reduced redress frequency

The Technology

The technology provides a compact, reliable and quick mechanism for shearing Slickline, Braided Line, E-Line and Coiled Tubing then fully closing to establish isolation or sealing of the well bore.

Low volume hydraulic actuators allow rapid closure with standard accumulator type control units. Intended for installation on or as close to the wellhead as possible. Ezi-Shear Seal products can be operated using existing or remote hydraulic control units.

The Design

The Ezi-Shear Seal compact design, in many cases, allows deployment through a standard offshore intervention hatch cover, negating the need to remove main hatch covers, reducing heavy lifts and potential shutting in of adjacent producing wells.

Its compact nature does not compromise its cutting capabilities and addresses the increasingly stringent industry requirements on shear and seal capabilities during well intervention operations.

The Innovation

Hunting's Ezi-Shear Seal leads the way in innovation for well intervention shear seal applications. With independent shearing and sealing faces, the Ezi-Shear Seal outperforms the capabilities of any other shear and seal valve currently on the market.

Hunting's unique Ezi-Shear Seal provides a superior cutting and seal capability for standard, offshore or high pressure applications where an additional level of pressure barrier contingency is required.

Hunting's Ezi-Shear Seal leads the way in innovation for well intervention shear seal applications.



Ezi-Shear Seal Valve & Ezi-Shear Seal Valve - Heavy Duty Technical Specifications

Technical Specifications / ESSV and ESSV-HD

	ESSV (5 1/8")	ESSV (6 5/8")	ESSV-HD (5 1/8")
Working Pressure	10,000 psi and 15,000 psi	10,000 psi and 15,000 psi	15,000 psi
Temperature Range	-29°C to 121°C / -20°F to 250°F	-29°C to 121°C / -20°F to 250°F	-10°C to 105°C / 14°F to 221°F
Valve Configuration	Single	Single	Single
Connections	Quick Union, API Flange and Customer Specific upon Request		

The above products also feature the following Design and Manufacturing Standards:

- API 6A
- PR1/PSL3 as Standard
- Material Class EE as Standard
- NACE MR 0175
- API 16A and NORSOK D-001, D-002 and D-010

Cutting Capabilities / ESSV and ESSV-HD

	ESSV	ESSV-HD
Slickline - 0.092" to 0.160"	✓	✓
Braided Line - 7/32" to 5/16"	✓	✓
E-Line Mono-Cable - 7/32" to 5/16"	✓	✓
E-Line Hepta-Cable - 7/16" to 0.520"	✓	✓
Coiled Tubing - 1.500" HS-90		✓
Coiled Tubing - 1.750" HS-80		✓
Coiled Tubing - 2.000" HS-130		✓
Coiled Tubing - 2.375" HS-130		✓
Coiled Tubing - 2.625" HS-130		✓
Coiled Tubing - 2.875" HS-130		✓

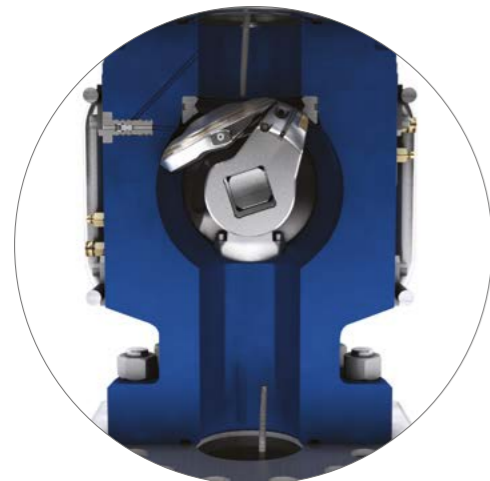

ESSV Shear and Seal Hepta Cable



ESSV-HD Shear and Seal Coiled Tubing

WIRELINER VALVES

Hunting Wireline Valves	13
EziClose® Hydraulic Cylinders	14
Wireline Valve Equalising Manifolds	15
Work / Protection Frames	16
Shipping Frames	17
Wireline Valve Rams	18

OVERVIEW

Used as a safety device in the event of problems occurring when running wireline into a well, the Wireline Valve (WLV) provides a positive seal, containing well pressure around stationary slickline or braided cable during well intervention operations.

Working on the principle of horizontally opposed rams coming together to centralise the wire and seal around it, the rams form a seal across the bore of the WLV.

Different WLV configurations are available from a single ram set through to quad ram sets. Ram sets can be fitted with either slickline, braided, multiline or even shear seal rams.

Hunting Wireline Valves

Wireline Valves

FEATURES

- Ram position indicator rods
- Hydraulic cylinder support rods
- Non-rising manual stems
- Xylan coated ram bores
- Can be supplied with flange/hub or quick union connections
- Inconel inlays available

BENEFITS

- External indication of the ram position
- Reduced manual handling when accessing the rams
- Stems stay inside the cylinder reducing damage potential
- Bore protection against corrosion
- Connection best suited to client needs
- Ultimate protection in volatile well conditions

Hunting manufacture different ranges of hydraulic WLV's, all with monoblock bodies and are available to suit standard or H₂S service.

Extreme cold weather options can be requested. The Hunting supplied WLV's are briefly described below:

Compact

The Hunting Compact range was designed to offer low weight and better serviceability with fewer parts. These are available in bore sizes 3" and 4-1/16" with working pressures up to 15,000 psi.

Conventional

This range covers 5-1/8" through to 9" wireline valves with working pressures up to 15,000 psi.

EziClose®

Available with bore sizes from 3" through to 9" with working pressures up to 15,000 psi. Developed to meet changing industry needs. See feature page for detailed description.

Hunting wireline valves are available fitted with all standard industry quick unions or flange/hub connections. WLV's can be requested with mixed connections.

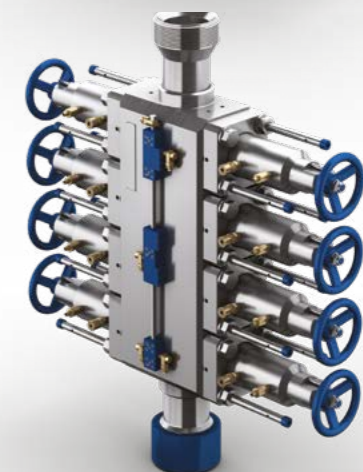
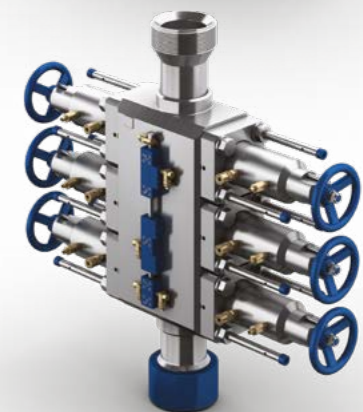
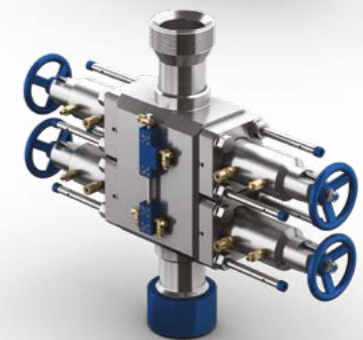
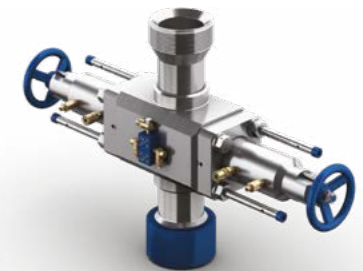

EziClose® Hydraulic Cylinders Wireline Valves



FEATURES

- Can be retrofitted to conventional and Compact type WLV's
- Complex type equalising assembly
- Ability to close the cylinder manually with WHP's up to 15,000 psi
- Pressure equalisation across the hydraulic cylinder system

BENEFITS

- WLV can be upgraded with latest design to improve performance
- Allows glycol or grease injection, monitoring and bleed off capabilities
- Should the client deem it required the WLV can be closed manually
- Reduced closure time, hydraulic closure pressure does not have to fight against well pressure

Hunting balanced piston EziClose® hydraulic cylinders can now be closed manually against well pressure and, when using accumulated pressure, close at a vastly reduced time compared to industry requirements.

EziClose cylinders can be retrofitted to both Compact and conventional WLV's enabling customers to meet newer industry standards by adapting previously bought WLV's.



Wireline Valve Equalising Manifolds Wireline Valves

FEATURES

- Equalisation across individual sets of rams, pairs or the whole system
- Allows glycol and grease injection, separate injection point with integral check valves
- Ports for attaching system monitoring and bleed off manifolds
- Stainless steel legend plate showing circuit diagram

BENEFITS

- Pressure can be guided to or from the required location with full integrity
- Having two separate entry ports in the WLV removes the potential for a separate chemical injection sub. The integral check valve reduces the potential of external damage
- No need for the traditional manifold on the lubricator and also easier to access
- Conveniently placed and easy to follow guide that will not corrode

There are two equalising systems available, basic or enhanced

Basic

An equalising system allowing equalisation across an individual ram set.

Enhanced

The enhanced equalising assembly enables equalisation across individual ram sets, pairs of ram sets and/or the whole system. They also allow for injection of grease and chemicals (two ports), bleed off and monitoring of the well bore fluids.

Basic and enhanced equalising assemblies use similar blocks, valves and spools across the whole WLV range allowing customers to keep minimal stock covering their different sized WLV's.



Work / Protection Frames Wireline Valves

Hunting can supply WLV Work Protection Frames for any WLV in their range.

This highly recommended accessory enables crew members to work at lubricator height using the drop down step.

These frames also provide protection to the equalising assembly, hydraulic cylinders and connectors whilst still allowing access to perform routine maintenance. Protection frames are available with certified lifting points.

FEATURES

- Work protection frame encompasses the WLV
- Provides a secure step/footing for crew
- Protect cylinder support rods whilst still allowing access for maintenance

BENEFITS

- Reduced exposure to damage when being rigged up
- Built in step gives a work platform at the WLV
- Cylinders can be opened and rams removed whilst still in the work protection frame



Shipping Frames Wireline Valves

FEATURES

- Large heavy duty steel frame that allows access by forklift truck or crane
- Provides internal protection with an easy pressure testing facility supplied
- Oil fill and drain system ensures bore parts remain in prime working condition
- All steel frames are supplied fully certified to BSEN12079 and DNV2,7-1 lifting specifications

BENEFITS

- Complete protection when shipping and transporting to the well site
- Can be tested immediately after maintenance
- Ensures bore parts remain in prime working condition
- Built as per industry standards

Wireline valves need to be stored appropriately to guarantee longevity and prevent expenditure on spares.

The best way to store and protect an expensive WLV is within a shipping / storage frame. The heavy duty steel frame not only provides external protection but when fitted with a test stump enables pressure testing within the frame.

An oil tank is built into the frame along with a simple hand pump so that WLV's can be filled with oil. No matter how long the WLV is left idle, and what the climate is, the working parts will remain in good working order. When the WLV is ready to be used the oil is simply returned to the tank.

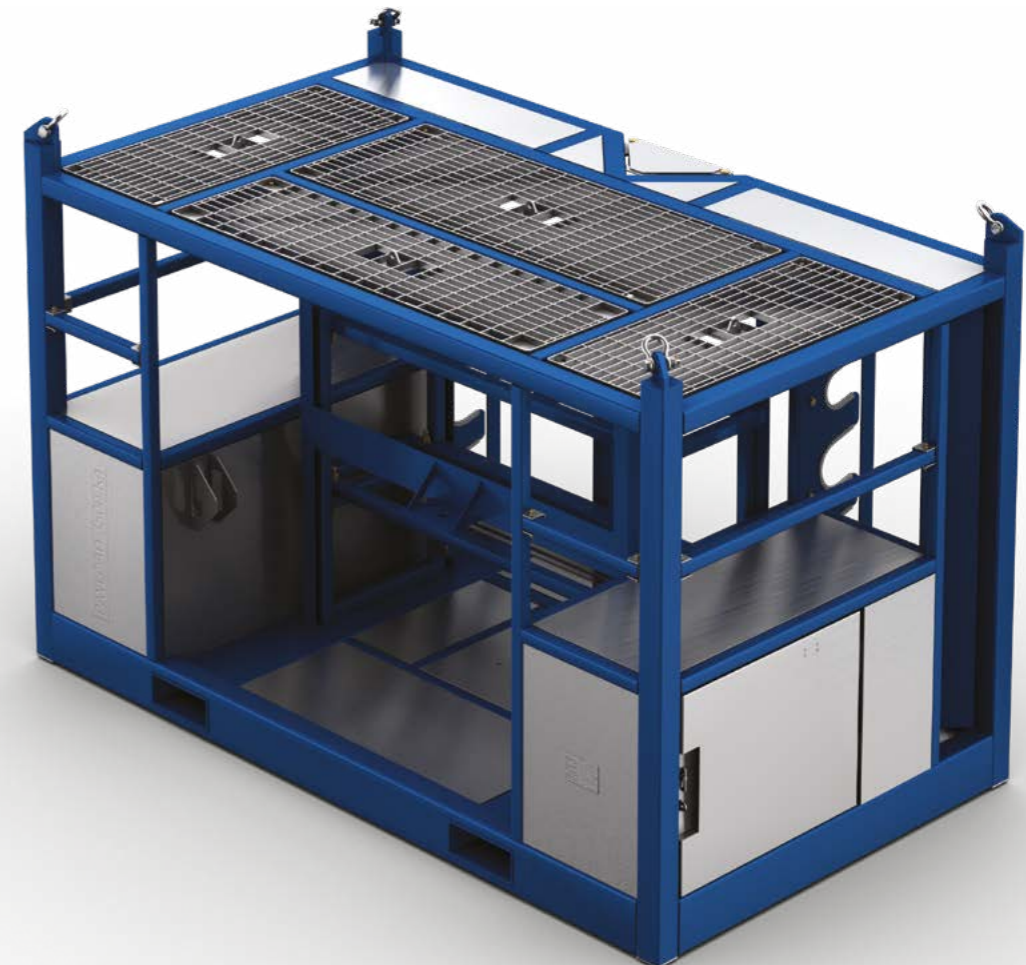

Wireline Valve Rams

Wireline Valves



Universal Rams

Hunting supply WLVs with various ram configurations to best suit the operational needs of the client.

The inner seals can be blind for slick line operations, cable sized for stranded line operations with profile to match line from 3/16" up to 15/32" or multiline type where the inner seal can be used across a range of slickline or stranded cables. Below are descriptions of the rams we regularly provide.

Universal Rams:

Designed for use when using Slickline, Cable sized or Multiline Type inner seals along with the correct wire guide.

X-Type Rams:

This ram type is recommended for use with 5-1/8" through to 9" wireline valves. The design was developed to eliminate the difficulties in sealing against broken in wire in large WLVs. The design ensures that the line will be centralised in the profile with no damage.

Shear Seal Rams:

Shear seal rams are all fitted with blind inner seals to create a barrier with no line present. The cutting blades will cut all lines up to 15/32".

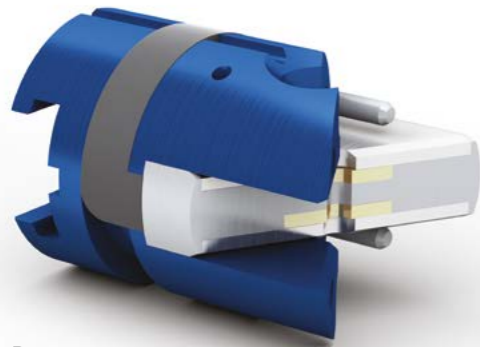

X-Type Rams

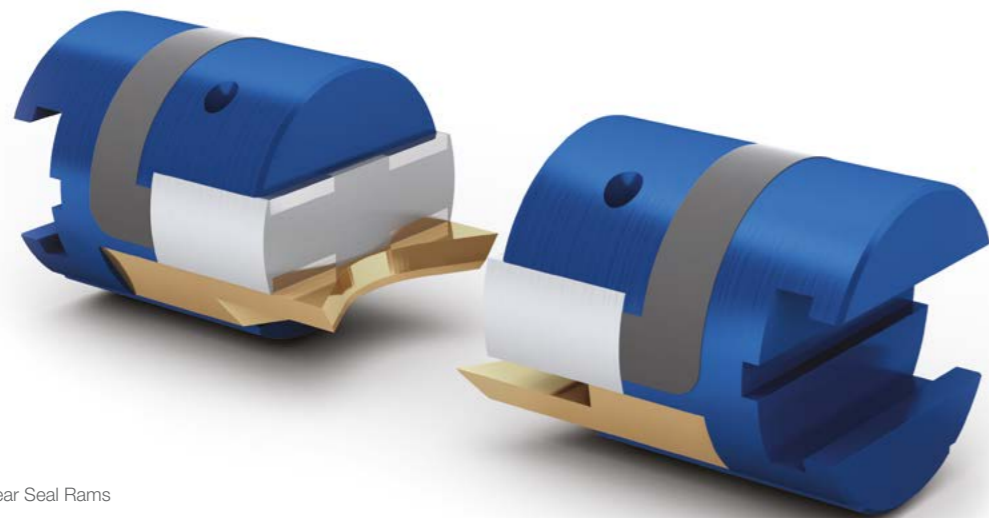

Shear Seal Rams



STUFFING BOXES

Hydraulic Slickline Stuffing Box	21
EziLoad® Slickline Stuffing Box	22
Liquid Seal Head	24
15K EziLoad® Liquid Seal	25

Hydraulic Slickline Stuffing Box Stuffing Boxes

FEATURES

- Guides the slickline from the bottom hay pulley into the top of the lubricator rig-up
- Contains well pressure whilst the slickline is either moving or stationary
- Upper and lower bushings ensure accurate alignment into the centre of the packing stack
- Brass internal components prevent slickline damage
- Sheave and bracket made from high quality castings
- Ball type check valve used instead of traditional blow out plunger

BENEFITS

- Light and user-friendly
- Materials used avoids damage
- Hard wearing and reliable
- Excellent seal characteristics
- Elastomers options available to suit specific applications
- Assembly supplied with load test certification

The Hunting Hydraulic Slickline Stuffing Box contains well pressure whilst the slickline is either moving or stationary and also guides the slickline from the bottom hay pulley into the top of the lubricator.

Slickline is passed over the sheave wheel and down through a hydraulic packing stack within the stuffing box body. Upper and lower bushings are provided to ensure that the slickline is guided into the centre of the packing stack. The hydraulic packing stack can be compressed from a safe distance should the packing leak due to wear.

The Hunting design philosophy is to create stuffing boxes that are rugged and reliable, whilst being as light and user-friendly as possible.

To avoid damaging expensive slicklines, internal components that are in contact with the wire are manufactured from brass, however other materials can be specified. A ball check valve is provided to prevent the escape of well fluids in the event of the slickline breaking.

The standard sheave bracket assembly is made from high quality castings, a composite or aluminium sheave can be selected. Free movement of the sheave and bracket is enabled by high quality taper roller bearings and each assembly is supplied with load test certification.

The sheave is either manufactured from composite or aluminium, depending on the application. It is available in 16-inch and 20-inch diameters to suit all slicklines up to 0.160-inches and each assembly is supplied with load test certification.

Stuffing boxes are available to suit almost any pressure and any union size, however we will supply equipment to suit customer's specific requirements.



EziLoad® Slickline Stuffing Box

Stuffing Boxes

FEATURES

- Separate light packing cartridge eliminates the need for the heavy part of the stuffing box to be connected to the upper lubricator
- A cam device simplifies the loading of wire onto the sheave
- Packing cartridge contains four rollers to ensure wires are tracked accurately
- Integral velocity ball check valve prevents the escape of well fluids

BENEFITS

- Overcomes the handling problem of increased weight and awkwardness of conventional slickline stuffing boxes
- Reduces the weight by 30 per cent
- Rollers offer secure wire retention and minimise wear
- Assembly supplied with load test certification

Hunting's revolutionary EziLoad® Slickline Stuffing Box was designed to overcome the manual handling problems caused by the increasing weight and awkwardness of conventional slickline stuffing boxes. In addition to achieving this goal, many other innovations were also introduced, resulting in the EziLoad® stuffing box being the most advanced stuffing box available.

Leaving the heavy part of the stuffing box connected to the upper lubricator and designing a separate packing cartridge as the only part that needs moving, has resolved the manual-handling problem. A conventional stuffing box can weigh 50kg or more, however the removed packing cartridge weighs in at only 14kg. A rope socket can be made up in this packing cartridge and loaded into the lubricator rig-up from the top. The body of the stuffing box offers a 2.750-inch through bore.

To allow the packing cartridge to be inserted or removed, the sheave bracket assembly pivots out of the way. As it does so, a cam device lifts three brass retainer rollers away from the sheave wheel, simplifying the loading of wire.

When returned to position, the rollers provide the most secure wire retention possible. The packing cartridge itself carries four additional rollers to ensure that the wire is perfectly centred at all times, minimising wear on the hydraulic piston, packing glands, packing and of course, the wire itself. The packing is larger than in a conventional stuffing box, resulting in improved sealing and wear characteristics. This is particularly significant as bigger slicklines become more common. To avoid damaging expensive slicklines, internal components that come in contact with the wire are manufactured from brass.

Within the packing cartridge is an integral velocity ball check valve, which prevents the escape of well fluids in the event of the slickline breaking. Additionally, the assembly has an integral injection facility. To compliment the conventional packing cartridge set up, additional clip-on modules can be supplied to provide a chemical injection bath facility, or even a 'liquid seal' grease injection facility (for the 15K MWP version).

There is a hydraulic pack off built into the top of the cartridge to allow compression of the packing from a safe distance should they start to leak due to wear.

EziLoad® Slickline Stuffing Box



The EziLoad® sheave is either manufactured from composite or aluminium, depending on the application. It is available in 16-inch and 20-inch diameters to suit all slicklines up to 0.160-inches and each assembly is supplied with load test certification.

The top load facility of the EziLoad® stuffing box can be enhanced through the use of an EziCatch® tool catcher and as such, both components can be supplied as a combined unit – the EziCombo®.

Liquid Seal Head Stuffing Boxes

FEATURES

- Provides primary seal and maintains pressure integrity when running into/out of well
- Effective on high-pressure or hostile wells, offering a seal with less friction
- Manufactured from materials with low-friction characteristics
- Requirement of a grease supply system capable of surpassing the expected well pressure

BENEFITS

- Minimal grease requirement
- Less friction than a conventional stuffing box
- Reduces drag on the wire



The Hunting Liquid Seal Head is used in conjunction with a conventional Hydraulic Slickline Stuffing Box to create the primary seal on a slickline, while maintaining pressure integrity when running in and out of the well.

These devices are particularly effective on high-pressure or hostile wells as they offer a seal with much less friction than a conventional stuffing box would on its own.

Pressure control is achieved by passing the wire through several closely-fitting flow tubes and pumping grease into the annulus between the wire and the flow tube, at a pressure slightly above well pressure. The close tolerance between the wire and the flow tubes, combined with the design of the interface between each flow tube, creates a sequential pressure drop such that there is no residual well pressure while the wireline exits the top of the flow tubes. This is exactly the same principle used for a braided line grease injection control head.

The Hydraulic Slickline Stuffing Box, which is mounted on top of the Liquid Seal Head, serves mainly an emergency pack off should the grease injection system fail. It also services the duties of wiping the wire and to guiding the slickline from the bottom hay pulley into the top of the Liquid Seal Head.

A grease supply system capable of surpassing the expected well pressure is required. However, due to the design of the Hunting Liquid Seal Head, the volume of grease required is minimal if flow tubes are sized correctly.

In order to avoid damaging expensive slicklines and to ensure the minimum possible drag on the wire, the flow tubes are manufactured from materials with very low-friction characteristics.

Hunting Liquid Seal Heads are available to suit any pressure and service, with any quick union, and can be set up to suit any size of wire from 0.092-inches to 0.160-inches. Changing the wire size simply requires the installation of a new set of flow tubes, which can be achieved very quickly.

15K EziLoad® Liquid Seal Stuffing Boxes

FEATURES

- Rated for 15K psi working pressure
- Utilises a removable cartridge system
- Uses industry proven design elements from Hunting's Ezi range
- Roller guides
- Ball check valves
- Enables offsite threading of wire through the cartridge
- Allows top loading of tool strings through the liquid seal body

BENEFITS

- Reduced rig up height
- Reduces potential damage to the line
- Safer operations
- Ease of manual handling

The Hunting 15K EziLoad® Liquid Seal Stuffing Box uses industry proven design elements from the successful EziLoad® stuffing box in a 15K option. Unlike traditional stuffing boxes, the seal is created by filling the void between flow tubes and the wire with viscous grease. One of the main benefits of this system is the creation of a reduced friction system that can aid jarring reaction and tool string selection.

The Hunting 15K EziLoad® Liquid Seal Stuffing Box is suitable for slicklines up to 0.160" with aluminium or composite sheaves matched to the line sizes selected.

The removable cartridge offers the benefits of being able to top load, the tool string through the liquid seal body (and EziLoad® tool catcher if fitted) with reduced potential damage to the line. Being able to slide the cartridge along the line and into position, whilst observing the process for issues, leads to a safer operation. Line damage can be time consuming and costly due to the introduction of technology cables. The Hunting EziLoad® Liquid Seal greatly reduces this risk.

The cartridge system reduces potential injury from manual handling. Guide wheels above the piston ensure that the lines run fully centralised reducing wire tracking damage to the piston and line.



TOOL CATCHERS

Hunting EziCatch® Tool Catcher	27
EziCombo Tool Catcher / Stuffing Box	28
Open Hole Tool Catcher	29

Hunting EziCatch® Tool Catcher Tool Catchers

FEATURES

- Ideally suited for use with the EziLoad® Stuffing Box
- A safety device designed to catch the toolstring in the lubricator
- The latch can support the weight of the toolstring and prevent it from falling back into the well

BENEFITS

- Allows for top loading of toolstrings when used in conjunction with the EziLoad® Stuffing Box
- Safety feature
- Supports the weight of a toolstring up to 500 kilograms

Hunting's EziCatch® Tool Catcher has two main benefits; it will catch fishing necks from 1.188" through to 2.313" and the through-bore of 2.75" allows top loading of toolstring.

Six fingers close into the bore when hydraulic pressure is released to catch the fishing neck.

The hydraulic operated function has the fail safe mode designed to stay latched should hydraulic pressure be lost ensuring the safety of the crew and can only be released when pressure is applied.



EziCombo Tool Catcher / Stuffing Box Tool Catchers



FEATURES

- Combines stuffing box and tool catcher into one short system
- Eliminate the requirement to purchase two separate units
- Removable packing cartridge
- 2.75 thru-bore offers top loading facility
- Multi catch tool catcher

BENEFITS

- Overcomes potential rig up height issues and reduced leak paths
- Cost saving solution to acquiring PCE
- Packing cartridge offers quick and easy redress saving on operational downtime
- Reduces manual handling issues by allowing the operator to quickly and safely load the toolstring with the stuffing box in situ
- Catches all standard fishing necks from 1.00" up to 2.313"

Hunting's EziCombo combines the patented EziLoad® Stuffing Box with the EziCatch® Tool Catcher producing an innovative combined assembly.

The two components go hand in hand both offering a 2.75 thru-bore to allow easy top loading access for toolstring components, reducing the likelihood of manual handling injuries.

The EziCombo eliminates the requirement for the join up quick union, reducing overall height, making it ideal where there are rig up height limitations.

Open Hole Tool Catcher Tool Catchers



FEATURES

- Interchangeable collets to suit all industry standard fishing necks
- Manufactured from light weight material
- Always in catch position
- Safe manual release system

BENEFITS

- Collets can be changed to suit standards industry fish necks 1.375" – 2.313"
- Light weight material used to aid manual handling
- Eliminate the possibility of a dropped toolstring, preventing injury to personnel within the work site
- Toolstring is broken down and released safely once the open hole tool catcher has been lowered

The Hunting Open Hole Tool Catcher has been developed to eliminate the possibility of a dropped toolstring during wireline open hole operations.

There is a possibility when pulling out of the well of the toolstring striking the top sheave causing wire failure and the toolstring to be released. The Open Hole Tool Catcher has a collet within the top sheave catcher assembly that will latch the fishing neck preventing the toolstring from falling, potentially causing damage or injury to personnel around the work site.

The captured toolstring can only be released by mechanical means once the system has been lowered to the ground.

Bespoke collet options available upon request.

GREASE HEADS

Cleanline Grease Injection Control Head	31
Cleanline Grease Injection Control Head - DLW (Dual Line Wiper)	32
Hydraulic Grease Head Cable Cutter	33
Chemical Injection / Inhibitor Sub	34

Cleanline Grease Injection Control Head Grease Heads

FEATURES

- Easy to add additional flow tubes
- Grease injection ball check safety feature

BENEFITS

- Additional flow tubes can be added for high pressure applications.
- Velocity ball prevents the escape of well fluids should the grease injection line or connection fail

Hunting Grease Injection Control Heads are designed to contain well pressure whilst running braided line or electric line cable operations.

Grease injection control heads are made up of two main assemblies, the pack off/line wiper assembly and the flow tube assembly.

The pack off assembly provides sealing capabilities when the wireline is stationary. Dual pack off's are available when higher well pressures are anticipated.

The line wiper is energised to clean the cable when pulling out of the well. The Hunting cleanline system incorporates an integral line wiper within the pack off assembly eliminating the requirement for a separate drain hose for the line wiper.

The flow tube assembly is made up of a number of close tolerance flow tubes that are sized to the diameter of the wireline/cable being used. Grease is then pumped into the annular void between the flow tube and the cable creating a pressure drop across each flow tube.

The number of flow tubes required is dependent on expected well pressures and well fluids.

An additional flow tube injection assembly can be added to provide more grease volume.



Cleanline Grease Injection Control Head - DLW (Dual Line Wiper) Grease Heads

FEATURES

- Dual line wipers - can be operated independently, with single return line, or simultaneously, with two independent return lines
- Easy to add additional flow tubes
- Grease injection ball safety feature

BENEFITS

- Having two Line wipers reduces downtime between pump-down jobs to service rubbers
- The dual line wipers can each have their own return line to use both line wipers at the same time. This places less stripping stress on each Line wiper rubber and extends further the time between rubber change-out.
- Additional flow tubes can be added for gas well operations.
- Velocity ball prevents the escape of well fluids should the grease injection line or connection fail

Hunting grease injection control heads are designed to contain well pressure whilst running braided line or electric line cable operations.

Grease injection control heads are made up of two main assemblies; the Pack off / Line wiper assembly and the flow tube assembly. The pack off assembly provides sealing capability when the wireline is stationary.

The line wiper is energised to clean the cable when pulling out of the well. The Hunting Cleanline system incorporates integral line wipers with a protective check valve between the Line wiper assemblies, eliminating the requirement for a separate second drain hose for the line wiper.

The flow tube assembly is made up of a number of close tolerance flow tubes that are sized to the diameter of the wireline / cable being used. Grease is then pumped into the annular void between the flow tube and the cable creating a pressure drop across each flowtube.

The number of flow tubes required is dependent on expected well pressures and well fluids. An additional flowtube injection assembly can be added to provide more grease volume. An in line Vent Valve can be installed below the bottom flowtube. Its use reduces the risk of adiabatic heating cable damage during wellsite pressure testing.



Hydraulic Grease Head Cable Cutter Grease Heads

FEATURES

- Shares same connection as flow tube assembly components
- Time-saving hydraulically operated system
- Guillotine type cutting system

BENEFITS

- Can be placed directly below the grease head
- Allows easy access for an operator to quickly cut the wireline
- Cutting system provides a clean cut of the cable to facilitate easier fishing situations

The Hunting Hydraulic Grease Head Cable Cutter offers a fast and simple way to cut wireline in the event of a stuck wire or birds nest situation in the grease injection control head.

Fitted directly beneath the bottom flow tube of the grease head, the hydraulic cable cutter provides a quick clean cut to allow for easier fishing in stranded armour situations, facilitating faster remedial work.



Chemical Injection / Inhibitor Sub Grease Heads

FEATURES

- Removable felt cartridge to change application
- Integral safety ball check valve

BENEFITS

- Same assembly can be utilised for both chemical or inhibitor injection
- Integral safety ball check valve

Hunting Chemical Injection and Inhibitor Subs are specially designed to aid the injection of inhibitor chemicals and de-icing agents onto the wireline or into the wellbore during routine operations.

The Inhibitor Sub contains felt packings which are soaked with inhibitor, coating the wireline as it passes through the sub.

By removing the felt packing cartridge the same assembly can be used as a chemical injection sub system when injecting de-icing agents.

Both systems incorporate a safety ball check valve to prevent well fluids being able to escape.



LUBRICATORS AND RISERS

Lubricators and Riser Sections

37

Lifting Clamps, Spreader Bars and Slings

38

Lubricators and Riser Sections Lubricators and Risers

FEATURES

- Fitted with industry standard quick unions
- Can be supplied in various lengths
- Threaded or integral design
- Lightweight design available

BENEFITS

- Provides compatibility with most surface pressure control equipment
- Promotes accurate rig up heights for a more manageable working window
- Threaded design allows for change out of quick unions
- Integral design reduces possible leak paths and reduces maintenance
- Offers significant weight saving on conventional lubricator designs

Hunting Lubricator and Riser Sections are designed to act as chambers for deploying wireline tools into the well whilst under pressure.

Lubricator/riser is available in various constructions:

- Conventional (Riser and Lubricator)
- Integral (Riser and Lubricator)
- Lightweight (Lubricator)
- Flanged (Riser)

Both lubricators and risers are available with quick unions.

Lubricators come in standard lengths from 2ft to 12ft and custom lengths are available on request including longer riser sections which are often used between the wellhead and rig floor.

Lubricator and riser can be ported with a ½" (0.50") NPT for up to and including 10,000psi WP. For working pressures above 10,000psi, 9/16" (0.56") Autoclave high pressure ports are supplied. Ports are available with a saver sub (replaceable port) option.



Lifting Clamps, Spreader Bars and Slings Lubricators and Risers

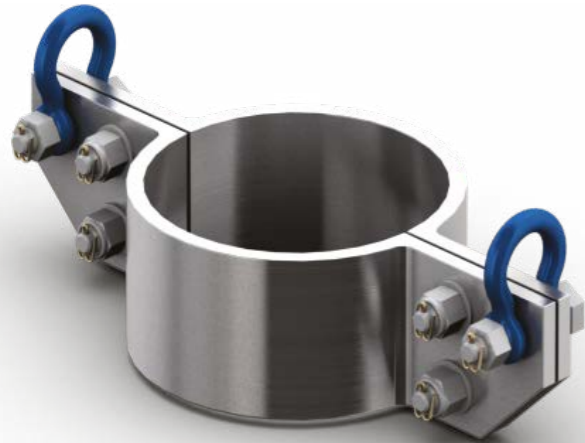

FEATURES

- Available in a range of sizes
- Hunting's lifting equipment is designed, manufactured, load tested and certified to meet current European legislation. (CE marked)

BENEFITS

- Lubricator lifting clamps and spreader bars are available to client requirements
- Tailored to suit specific applications

Hunting manufactures and supplies a wide range of lubricator lifting clamps and spreader bars, suitable for lifting lubricators and surface pressure control equipment in a safe and controlled manner.

Our lubricator lifting clamps are available for all sizes and type of lubricators in our product range. There is also a spreader bar and/or sling set suitable for every clamp and application, whether intended for slickline or electric line service.

In addition to our standard range, tailored lifting items to suit specific needs or preferences are available.

Each lubricator lifting clamp and spreader bar is designed, manufactured, load tested and certified.

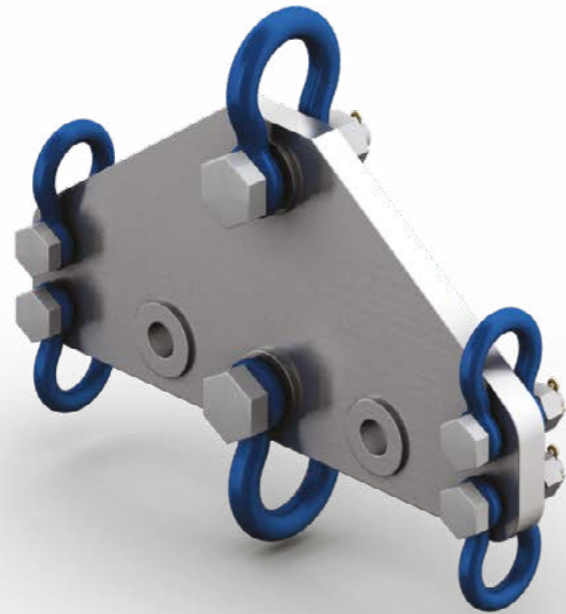

TOOL TRAPS

Hydraulic Tool Trap

41

Hydraulic Tool Trap Tool Traps

FEATURES

- Single flapper designed to accept tool weight from above
- Large 'V' slot to prevent cable damage

BENEFITS

- Small hydraulic chamber allowing efficient hand pump operation
- Compact assembly height

Hunting Hydraulic Tool Traps are available to suit various working pressures and manufactured to meet client operational needs.

There are two main operational types that share common features:

- External visual indication of the tools passing the flapper
- Either hydraulic open and spring return or hydraulic open and hydraulic close

The flapper that sits across the bore preventing tools from passing have a large 'V' slot to allow wire movement with reduced contact when the flapper is closed.



COILED TUBING PRESSURE CONTROL EQUIPMENT

ESSV-HD	43
Coiled Tubing BOP	44
Coiled Tubing In-Situ Pressure Test Sub	45
Coiled Tubing Stripper	46

Ezi-Shear Seal HD (ESSV HD) Coiled Tubing Pressure Control Equipment

FEATURES

- Cuts standard and high grade Coiled Tubing
- Cuts Slick Line, Braided Line and Mono/Hepta E-Line
- Independent shear and seal faces
- Dual hydraulic actuator
- Highly resistant to wear

BENEFITS

- Improved safety and reliability
- Compact design gives improved wellhead access
- Reduced leak paths and redress frequency

Introducing the Ezi-Shear Seal HD (ESSV HD), a shear and seal valve which delivers improved operational safety, reliability and well integrity during coiled tubing operations.

Hunting's ESSV-HD, Ezi-Shear Seal Valve continues to lead the industry with the new generation for Well Intervention shear seal solutions.

The ESSV-HD offers enhanced capabilities for cutting larger, thicker and higher grade Coiled Tubing and providing well pressure control following the cut.



Coiled Tubing BOP

Coiled Tubing Pressure Control Equipment

Hunting's Coiled Tubing BOP provides wellbore isolation, protection against blow-outs and secures the well in an emergency. The balanced piston design system increases shear capabilities.

Hunting's Coiled Tubing BOP has been designed and tested in accordance with API 16ST, API 6A, 16A, NORSOK D-001, D-002, D-010 and NACE MR0175.

FEATURES

- Rapid closure time
- Balanced Piston Design System, no additional load delivery system required
- Single open/single close line hookup
- Integral Hydraulic Opening System
- API Integral Flange Connection
- API Side Port
- Interchangeable Actuators
- Equalising Blocks

BENEFITS

- Minimal leak paths
- Balanced Piston Design increases shearing capabilities
- Manual closure under well bore pressure
- Reduced spares with simplified maintenance
- Hydraulically assisted re-dress



Coiled Tubing In-Situ Pressure Test Sub

Coiled Tubing Pressure Control Equipment

FEATURES

- Two O'ring seals to pressure test against via a port
- Multi range of flange connections and pressure ratings
- Internal bore size range from 3.00" - 9.00"
- Pressure tested hydraulically with a hand pump
- Hunting Coiled In-Situ Test Sub centre connection lifting/test cap available

BENEFITS

- Reduces the time spent pressure testing the rig up prior to exposing it to live well pressure
- The rig up can be tested whilst pressure sensitive equipment, such as perforating guns are in the riser
- Coil Tubing In-Situ Test Sub integral to the CT BOP will save rig up height

The Hunting In-Situ Pressure Test Sub was originally designed to reduce time spent pressure testing the broken lubricator connection after tool changes.

The Coiled Tubing In-Situ Pressure Test Sub takes the place of the bottom connection, effectively becoming the tool change joint that has to be broken. As a result of its unique design, it can be tested in isolation to the rest of the rig-up, by the simple use of a small hand pump.

The mid-joint of a Coiled Tubing In-Situ Pressure Test Sub is like any other quick union, except that it has two O-ring seals with a pressure test port between them. This feature is responsible for easy testing of joint integrity.

As noted, this saves pressure testing the whole rig-up, however there is another added advantage in that it allows for the riser system to be pressure tested whilst pressure sensitive equipment (such as perforating guns) are in the riser.



Coiled Tubing Stripper

Coiled Tubing Pressure Control Equipment

The Hunting Coiled Tubing Stripper comes with either single or dual independent packers. It is designed to seal around coiled tubing as it is stripped in and out of the well bore at max working pressures of 15,000psi and temperature between -29°C to +121°C. The piston(s) double as a sleeve that can be hydraulically actuated to expose the split packing and anti-extrusion rings, enabling quick redress with coiled tubing in the well.

The Hunting Coiled Tubing Stripper has removable guide sleeves available in a range of lengths to minimise the distance to the injector chains, reducing the chance of the coiled tubing buckling in snubbing conditions.

The Hunting Coiled Tubing stripper has two safety doors that are simply locked in position when closed. In the event of hydraulic failure, the doors will prevent the piston from retracting from the locked position until hydraulic control is regained.

FEATURES

- Side door access
- Compact
- Accepts industry standard packer rubbers

BENEFITS

- Packer rubbers can be changed out with CT in the wellbore
- Ease of use
- Minimise stock of stripper rubber



Coiled Tubing Stripper

Coiled Tubing Pressure Control Equipment

Connection Details

Connection Type	Quick Union or API Flange
Coil Size	1.00 to 2-3/8 (per requirement)
Hydraulic Connection Type	NPT
Hydraulic Connection Size (Inches)	1/2
Injection Connection Type	Autoclave
Injection Connection Size (Inches)	9/16

Dimension: (Ref Sketch)

	Single	Dual
Overall Height (Inches / mm) A	43.3" / 1100	56.4" / 1433
Maximum Diameter (Inches / mm) B	15.0" / 381	
Gross Weight (Pounds / Kg)	635 / 288	948 / 430

Working Conditions

Maximum Working Pressure (PSI)	15,000
Test Pressure (PSI)	22,500
Hydraulic Working Pressure (PSI)	5,000
Primary Environmental Condition	H2S

Working Temperatures

Min Operating Temperature (°F / °C)	-20 / -29
Max Operating Temperature (°F / °C)	250 / 121

Design Criteria

API 6A (Latest Edition)	Yes
NACE MR 01 75 (Latest Edition)	Yes

Testing Criteria

API 6A (Latest Edition)	Yes
-------------------------	-----

Illustrations (figures) provide a graphical representation of equipment components or screen snapshots for use in identifying parts, or establishing nomenclature, and may or may not be drawn to scale. For component information specific to your rig configuration, see the technical drawings included with your equipment documentation.

EZI-LATCH

Ezi-Latch (Hydraulic Wellhead Connector)

49

Ezi-Latch (Hydraulic Wellhead Connector) Stand-Alone Products

FEATURES

- Hydraulically controlled connection
- Night cap lifting arm with stow-away seal protection
- Failsafe design
- 15,000psi working pressure
- Large entry guide funnel
- Indicator rods to verify locked/unlocked position

BENEFITS

- Reduces personnel exposure in the red zone
- Ease of use
- -18°C to +121°C (0°F to 250°F) temperature range
- Fast connection changes
- Reduces risk of injury
- Reduces rig up time

The Hunting Ezi-Latch (Hydraulic Wellhead Connector) is designed to quickly connect the Pressure Control Tool String or Night Cap to the Wellhead using hydraulics, removing human intervention and risk of injury.

Our simplicity in design, developed from our existing Ezi-Catch Tool Catcher, will make rigging up and down quicker, safer and easier for our customers.

The failsafe design features 3 hydraulic cylinders that are remotely actuated to set a lock ring securing the Ezi-Latch connection and lock it in position. Once locked in place, it provides a pressure tight barrier to begin operations, controlled via a stand alone hydraulic control panel.

The unique profile of the lock ring and the use of springs ensure the lock ring will always stay in position in the event of hydraulic failure.



1 Arm in locked position

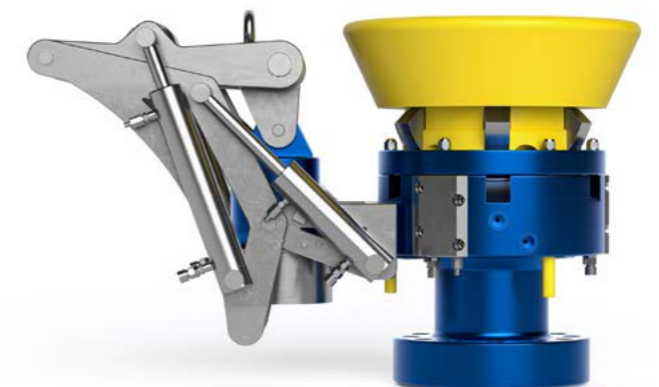

2 Arm in unlocked position

STAND-ALONE PRODUCTS

Hydraulic Line Wipers	51
Hydraulic Pack Off	52
Turnaround Sheave	53
PCH Stripper - Type 2	54
PCH Stripper - Type 3	55
In-Situ Pressure Test Sub	56
Pump-In Sub	57
Ball Valves	58
Hay Pulleys / Sheaves	59
Quick Union Rig Up Dolly	60

Hydraulic Line Wipers Stand-Alone Products

FEATURES

- Quick union connection
- Hydraulic functioned element
- Top funnel
- Brass upper and lower glands
- Split rubber element

BENEFITS

- Can be fitted above the original grease heads fitted with only a pack off
- Pressure can be applied hydraulically to the line wiper
- The top funnel is to protect the wire from damage whilst in operation and rigging up/down
- Brass upper and lower glands ensure the wire runs central in the element
- Element can be replaced with cable through the wiper assembly

The Hunting Line Wiper is supplied with a cable protector funnel on top and a quick union. This is traditionally fitted above grease injection heads fitted with only a pack off.

Brass upper and lower packing adapters guide the cable through the rubber element, delivering the wiping effect. When retrieving tools from the well, the wiper seal is gently compressed to tighten against the cable hydraulically.

Elements are available to suit different well conditions.



Hydraulic Pack Off Stand-Alone Products

FEATURES

- Quick Union connections
- Single or dual pack off available
- Top funnel
- Brass upper and lower packing adaptors
- Split rubber element

BENEFITS

- Used during swabbing operations as emergency barrier
- Dual pack off provides additional barrier
- Pressure can be applied hydraulically to the pack off elements
- The top funnel is to protect the wire from damage whilst in operation and rigging up/down
- Brass upper and lower glands ensure the wire runs central in the element
- Element can be replaced with cable through the pack off assembly

The Hunting Pack Off is supplied with a cable protector funnel on top and a Quick Union or tubing connection at the base.

Brass upper and lower packing adaptors guide the cable through the rubber element. When performing swabbing operations, should the well start to 'come in,' the elements can be hydraulically activated to provide a low pressure seal against the cable.

Elements are available to suit different well conditions.



Turnaround Sheave Stand-Alone Products

FEATURES

- Reduces the rig-up height of e-line operations by turning the wire 180 degrees so it points downwards rather than upwards
- Lack of central hub keeps weight to a minimum
- Use of Finite Element Analysis (FEA) to ensure reliability, light weight and user-friendliness

BENEFITS

- Reduces the rig-up height by turning the wire to face downwards rather than upwards
- The alternative 2-inch 10-flow tube connection removed a quick union connection

The Hunting Turnaround Sheave offers operators the opportunity to reduce their rig-up height during e-line operations, by turning the wire through 180 degrees whilst still within the pressure control equipment (PCE). This allows for the grease injection control head to be pointing downwards instead of upwards.

Typically, the Turnaround sheave would be mounted on top of a tool catcher with a grease injection control head suspended from the other side.

Essentially a pressurised top block, the turnaround sheave consists of a sheave wheel held within a pressure retaining housing. By creating the assembly without a central hub, weight is kept to a minimum. The sheave is a precision-machined ring, which rotates on a large bearing to which grease can be pumped into for lubrication.

Turnaround sheaves can be supplied with any of the standard quick unions in order that it can be assembled directly to a suitably configured tool catcher and grease injection control head. If required, an alternative 2-inch 10-flow tube box connection can be provided on one side of the sheave body to eliminate a quick union.

Accessories available for the Turnaround Sheave include:

- Grease Injection Control Head Clamps
- Fixed Floor Blocks
- Grease Catchers

As with all Hunting PCE, great effort has been made to create a product that is rugged and reliable, whilst being as light and as user-friendly as possible. To achieve this, extensive use of Finite Element Analysis (FEA) has been used in the design.



PCH Stripper - Type 2 Stand-Alone Products

FEATURES

- Available in 10,000 psi and 12,500 psi versions
- Slim body, no external springs
- Lubrication injection and check valve assembly
- Simple to install
- Sealing elements are same for all versions of the PCH
- Line components can be removed and elements changed while cable is threaded through the assembly without the need of a full strip down
- Ported for inject/vent valve capability (adiabatic heating operations)

BENEFITS

- Reduces the weight and operational risks associated with manual handling
- Ease of installation saves valuable operation time
- Efficient servicing when changing the elements

The Hunting Pressure Control Head (PCH) Stripper is designed to seal around greaseless wireline using hydraulic pressure. This prevents well fluids and/or gases within the lubricator from polluting the well site as the wireline is run in and out of the well bore.

The Type 2 PCH is available for working pressures up to 12,500 psi, with an extensive and proven field history compatible with any brand of greaseless cable.

There is a grease injection port between the pack offs to initially lubricate the dry line during run in hole, but also reducing friction and enhancing the life of the elements. An additional injection port has also been included on the top funnel to lubricate the line before entering the PCH.

A PCH Stripper has a dual configuration and a rated working pressure of 12,500 PSI. Connections used to attach the PCH Stripper to the lubricator are most commonly of the self-aligning quick union type. Other customer specified connections are available upon request.

All PCH Strippers incorporate a safety check valve, should the line break and be pulled out of the PCH Stripper Packing. In this event, as the well pressure tries to escape through the hole left in the Check Valve Housing, it will force the safety check valve ball bearing up.



PCH Stripper - Type 3 Stand-Alone Products

FEATURES

- Designed for working pressures up to 15,000 PSI
- Interchangeable modular system that can be run in Single, Dual, Triple, or any number of configurations
- Improved wear resistance on internal brass and rubbers
- Less parts, extremely easy to assemble and service while on job site
- Line components can be removed and elements changed while cable is threaded through the assembly without the need for additional equipment option.
- Ported for inject/vent valve capability (adiabatic heating during operations)

BENEFITS

- Standardised, interchangeable parts simplifies inventory
- Reduces the weight and operational risks associated with manual handling
- Ease of installation saves valuable operation time
- Service components reduce the frictional bind and wear on seals

The Hunting Pressure Control Head (PCH) Stripper is designed to seal around greaseless wireline using hydraulic pressure. This prevents well fluids and/or gases within the lubricator from polluting the well site as the wireline is run in and out of the well bore.

The introduction and improvements with the Hunting Type 3 PCH is a major step change in the performance, operational flexibility and ease of maintenance when running coated wirelines.

There is a grease injection port between the pack off modules to lubricate the dry line during run in hole reducing friction and enhancing the life of the elements. An additional injection port has also been included on the top funnel to lubricate the line before entering the PCH.

The PCH Type 3 Stripper can be run in single, dual, triple (or quad) configurations, each with a pressure rating of 15,000 PSI. Connections used to attach the PCH Stripper to the lubricator are most commonly of the self-aligning quick union type. Other customer specified connections are available upon request.

All PCH Strippers incorporate a safety check valve, should the line break and be pulled out of the PCH Stripper Packing. In this event, as the well pressure tries to escape through the hole left in the Check Valve Housing, it will force the safety check valve ball bearing up.



In-Situ Pressure Test Sub Stand-Alone Products

FEATURES

- Two O-ring seals to pressure test against via a port
- Multi range of quick union connections and pressure ratings
- Internal bore size range from 3.00" – 9.00"
- Pressure tested hydraulically with a hand pump
- Can be supplied to special order and connected directly to the Wireline Valve
- Hunting In-Situ Test Sub centre connection lifting/test cap available

BENEFITS

- Reduces the time spent pressure testing lubricators prior to exposing it to the live well pressure
- The rig up can be tested whilst pressure sensitive equipment, such as perforating guns are in the lubricator
- In-Situ Test Sub connected directly to the wireline valve will save rig up heights
- Time saving benefits

The Hunting In-Situ Pressure Test Sub was originally designed to reduce time spent pressure testing the broken lubricator connection after tool changes.

The In-Situ Pressure Test Sub takes the place of the bottom connection, effectively becoming the joint that has been broken. As a result of its unique design, it can be tested in isolation to the rest of the rig-up, by the simple use of a small hand pump.

The mid-joint of an In-Situ Pressure Test Sub is like any other quick union, except that it has two O-ring seals with a pressure test port between them. This feature is responsible for easy testing of joint integrity.

As noted, this saves pressure testing the whole lubricator rig-up, however there is another added advantage in that it allows for the lubricator system to be pressure tested whilst pressure sensitive equipment (such as perforating guns) are in the lubricator.

In-situ Pressure Test Sub centre connections fitted directly to WLVs or other equipment, saving in rig-up height, can be supplied by special order.



Pump-In Sub Stand-Alone Products

FEATURES

- Large bore 2" through bore on side arm
- Hunting flanged joint that uses elastomer seals or the API flange metal ring gasket types are available

BENEFITS

- Effective for large volume hydrostatic testing or pumping high volumes into the well
- Standard industry WECO connections

Hunting Pump-In Subs are designed to provide a large flow fluid entry path into the pressure control equipment (PCE) for hydrostatic testing, or for pumping fluid into the well.

Pump-In Subs can be supplied to suit any application, with either quick union connections or flanges. The inlet ports are usually 2.00" 1502 WECO type for 10,000psi and below, or 2.00" 2202 WECO type for above 10,000psi.



Ball Valves

Stand-Alone Products

FEATURES

- Redesigned and taken advantage of the Finite Element Analysis to reduce size and weight, without losing functionality or strength
- Hydraulically operated
- Ball valves are available that cut wire

BENEFITS

- 30 per cent reduction in weight
- Functional, reliable and easy to use

The Hunting Ball Valve is a fully opening, hydraulically controlled valve, designed to hold pressure from above and below.

It can be used:

- In a pressure control string, either above or below the wireline valve (WLV), as an additional wellhead valve
- For testing the pressure control string prior to running tools into the well

The latest Hunting Ball Valves have been redesigned, taking advantage of Finite Element Analysis (FEA) to reduce size and weight, resulting in a product that is 30 per cent lighter than its predecessor, with no loss of strength or functionality.

The design itself is very simple, consisting of a precision-machined ball between two floating seats, operated by a hydraulically actuated shuttle. An equalizing valve has been incorporated into the design to ensure that there is no undue stress on the mechanism when opening the valve. Great thought has been put into making the valves easy to strip and redress, and creating a product that is functional, reliable and user friendly.

Some customers may want the ability to cut wire with a ball valve, for this application Hunting recommend a different ball valve that cuts only but does not seal.



Hay Pulleys / Sheaves

Stand-Alone Products

FEATURES

- Use the same sheaves and bearings as Hunting stuffing boxes which minimises the need for excessive stocking of spares
- Made of heavy duty aluminium alloy frame
- Features a loading gate to prevent the wire becoming misplaced during operation
- Fully tested and supplied with appropriate documentation

BENEFITS

- Suitable for all wire sizes and can be fitted to any of the Hunting Pulley's range
- Minimises the need for stocking of spares as uses the same bearings and sheaves as other products within the Hunting product line
- Safety features to ensure wire does not become misplaced during operation
- Made with a heavy duty aluminium alloy frame and featuring precision taper rollers which make it durable

Hay Pulleys are designed and manufactured to withstand the loads of slickline and braided cables, in addition to the 'wear and tear' of life at the rig site.

They consist of a heavy-duty aluminium alloy frame and an aluminium or composite sheave wheel. The load is taken up through a swivelling eye at the top, whilst wire is introduced through a loading gate, preventing it from jumping out during operations. The sheave wheel rotates on precision taper roller bearings.

Floor stands are available for all sizes, as are line wipers.

All hay pulley assemblies are fully load tested and supplied complete with the appropriate documentation.



Quick Union Rig Up Dolly Stand-Alone Products



FEATURES

- Threaded to the lower union to ensure it does not move during rig-up process
- Polyurethane or Foam Filled Pneumatic tyre options to suit a range of terrain in onshore or offshore environments Eradicates risk of damage to the lower union
- Available in all common Hunting quick unions

BENEFITS

- Safely moves lubricators
- Reduces potential damage to lower QU connection

The Hunting Quick Union Rig Up Dolly is designed to be attached to the bottom of the lubricator providing a roller system to aid the movement of the lubricator when rigging up / down pressure control equipment.

The quick union rig up dolly is simply threaded onto the lower union, so that it is unable to come off during the rig-up process. It has a steel axle and two heavy-duty wheels that support the weight of the lubricator whilst it is being brought into position, irrespective of the lift angle.

Available to suit all Hunting quick unions, the rig-up dolly is also offered to suit in-situ middle joint connections.

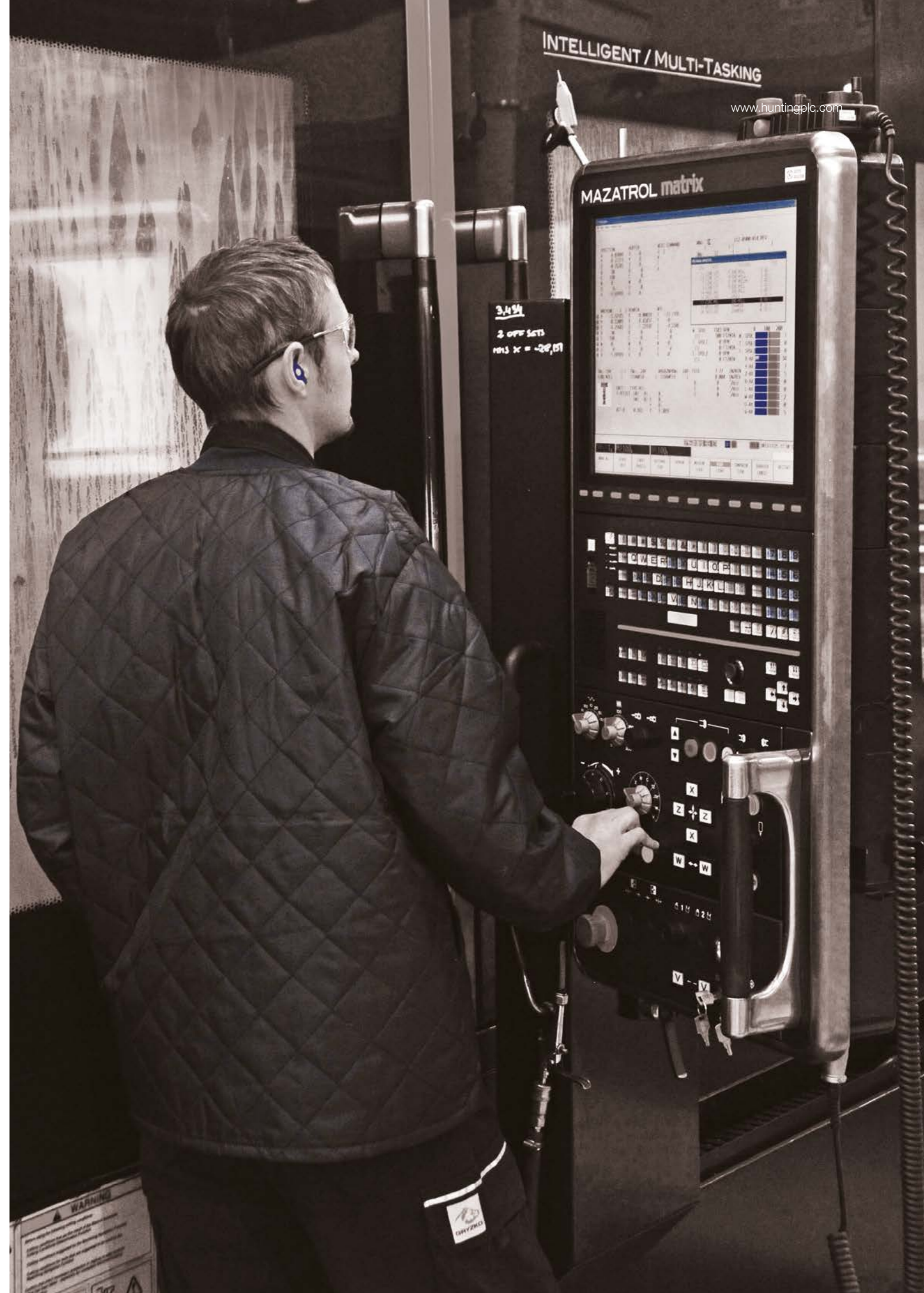

ADAPTERS

Crossover Adapters

63

Crossover Adapters Adapters

FEATURES

- Connection combinations to suit requirements (some examples below)
 - Quick union to quick union
 - Quick union to flange
 - Flange to threaded connection
 - Quick union to threaded connection
 - Threaded connection to threaded connection
- Fully certified designs, with reference to API (6A and 5CT)

BENEFITS

- Ease of adapting between connections
- Utilise existing equipment on different sized wellheads
- Designed and manufactured to meet industry standards

Crossover Adapters are available in various configurations which can include API flanges, quick unions and thread connections.



ANCILLARY ITEMS

Quick Union Test Equipment	65
Quick Union Lift / Test Cap	66
Quick Union Lifting Cap	67

Quick Union Test Equipment Ancillary Items

FEATURES

- Test cap fitted with internal thread for test rod holder
- Threaded ports on assemblies
- Lift/test caps are all CE marked

BENEFITS

- Safely contains test rod during WLV testing
- Reduced manual handling of test fixtures
- Fully tested and certified

Hunting Quick Union Test Caps are designed to fit into a Quick Union Box and can be used for pressure testing of pressure control equipment. The assembly consists of a quick union collar and a body with an integral test port.

Quick Union Test Stumps fit into the pin and collar and are fitted with a side port. These are also supplied with threaded holes where eye bolts can be used to aid manual handling.

Test assemblies are available for our quick union connections. Each test fixture is fully tested and certified.

Lift/test caps are available to suit all of our quick union connections, H₂S service is available upon request.



Quick Union Lift / Test Cap

Ancillary Items

FEATURES

- Manufactured with one piece of steel to give absolute security when making the lift
- Available for every union
- Load tested and certified by third party

BENEFITS

- One cap for both lifting and testing applications
- Convenient and safe way of capping-off a WLV that is left on the wellhead

Hunting Quick Union Lift Caps share the duties of a pressure test and lifting component. These can be used as an efficient means of moving then pressure testing equipment. They also offer a convenient and safe way of capping-off a WLV remaining on a wellhead.

Unlike a Quick Union Lifting Cap, the Lift / Test Cap has a complete union pin, collar and test port. The integral eye offers a means of connection to the lifting device.

With safety being our number one priority, the main body of our Quick Union Lift / Test Caps is manufactured from one piece of steel, ensuring absolute security when making a lift.

For further security, our Quick Union Lift / Test Caps are designed to meet all current lifting regulations and are load tested, pressure tested and certified by a third party to a specific working load.



Quick Union Lifting Cap

Ancillary Items

FEATURES

- Manufactured with one piece of steel to ensuring absolute security when lifting rather than threaded eye bolts
- Meets all current lifting regulations
- Load tested and certified by third party
- Available for all Hunting quick unions

BENEFITS

- Safely manufactured using one piece of steel

Hunting Quick Union Lifting Caps offer a safe and convenient method of lifting pressure control equipment such as wireline valves and riser sections etc. The Cap is simply threaded onto the top union of the item to be lifted. The integral eye offers the means of connection to the lifting device.

Hunting Quick Union Lifting Caps are available for all Hunting quick unions.

With safety being Hunting's number one priority, our standard Quick Union Lifting Caps are manufactured from one piece of steel, ensuring absolute security when making a lift.

For further security, our Quick Union Lifting Caps are designed to meet all current lifting regulations, are load tested and certified to a specific Safe Working Load by a third party.

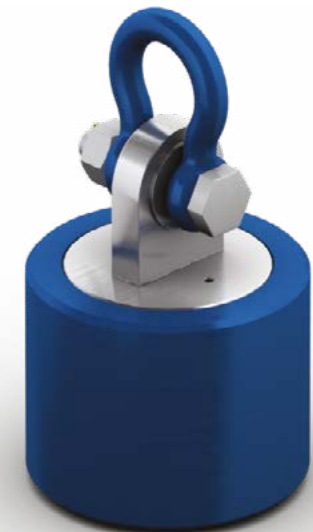

Quick Union Reference Table / Technical Information

Thread	Seal Diameter	Bore	Pressure	Service	'O' Ring
Otis Type					
5.000-4	3.500	2.500 / 2.920	10,000	STD	306-3038-000
5.000-4	3.500	2.500 / 2.920	5,000	H ₂ S	306-3038-000
5.000-4	3.500	2.500 / 3.000	10,000	STD	306-2036-000
5.000-4	3.500	2.500 / 3.000	5,000	H ₂ S	306-2036-000
5.000-4	3.500	2.500	15,000	H ₂ S	306-3038-000
5.750-4	4.000	3.000	10,000	H ₂ S	306-3042-000
6.000-4	4.875	4.000	5,000	STD	306-3049-000
6.250-4	4.000	2.500	15,000	H ₂ S	306-3042-000
6.500-4	4.750	3.000	10,000	H ₂ S	306-3048-000
6.500-4	4.750	4.000	5,000	H ₂ S	306-3048-000
6.500-4	5.188	4.000	5,000	H ₂ S	306-2049-000
6.500-4	5.250	4.000	5,000	H ₂ S	306-3052-000
7.500-4	5.500	3.000	15,000	H ₂ S	306-3054-000
8.250-4	6.188	5.000	10,000	STD	306-4034-000
8.250-4	6.188	5.000	5,000	H ₂ S	306-4034-000
8.375-4	5.250	4.000	10,000	H ₂ S	306-4027-000
8.750-4	7.500	6.375	5,000	H ₂ S	306-4041-000
9.000-4	6.750	5.000	10,000	H ₂ S	306-4038-000
9.500-4	8.000	6.375	5,000	H ₂ S	306-4043-000
9.500-4	6.250	4.000	15,000	H ₂ S	306-4035-000
11.500-4	8.250	6.375	10,000	H ₂ S	306-4044-000
12.000-4	10.313	9.000	5,000	H ₂ S	306-4048-000
12.250-4	7.000	5.125	15,000	H ₂ S	306-4039-000

Lightweight and Hunting Unions

4.750-4 x 2	3.750	3.000	10,000	H ₂ S	306-3040-000
6.125 - 4 x 2	4.750	4.125	10,000	H ₂ S	306-3048-000
6.875-4	5.250	4.000	6,500	H ₂ S	306-3052-000
7.875-4 x 2	6.125	5.125	10,000	H ₂ S	306-3059-000
9.500-4 x 2	6.250	4.000	15,000	H ₂ S	306-4035-000
11.500-4	8.625	7.375	5,000	H ₂ S	306-4045-000
12.000-4 x 2	10.250	9.000	5,000	H ₂ S	306-3076-000
12.875-4	10.625	9.000	6,500	H ₂ S	306-4049-000
14.125-4 x 2	9.000	7.062	15,000	H ₂ S	306-1412-001

Bowen Type

4.750-4	3.750	3.000	5,000	H ₂ S	306-3040-000
4.750-4	3.750	3.000	10,000	STD	306-3040-000
5.500-4 x 2	4.375	3.000	5,000	H ₂ S	306-3045-000
5.500-4 x 2	4.375	3.000	10,000	STD	306-3045-000
6.000-4 x 2	4.875	3.000	5,000	H ₂ S	306-3049-000
6.312-4	4.375	2.500 / 3.000	10,000	H ₂ S	306-3045-000
6.312-4	3.750	2.500	15,000	H ₂ S	306-3040-000
6.312-4	4.375	3.000	10,000	H ₂ S	306-2042-000
7.000-5SA	5.250	4.000	5,000	H ₂ S	306-4027-000
7.000-5SA	4.375	3.000	15,000	H ₂ S	306-3045-000
8.250-4 x 2	6.000	4.000	10,000	H ₂ S	306-2056-000
8.250-4 x 2	6.750	5.000	5,000	H ₂ S	306-4038-000
8.8750-4 x 2	6.500	5.000	10,000	H ₂ S	306-4037-000
9.875-4 x 2	8.000	6.375	5,000	H ₂ S	306-4043-000
13.000-4	9.500	7.375	10,000	H ₂ S	306-4047-000
13.500-4	10.000	7.375	10,000	H ₂ S	306-4048-000





© Hunting | All Rights Reserved