



U.S. Department
of Transportation

Research and
Special Programs
Administration

400 Seventh Street, S.W.
Washington, D.C. 20580

The US Department of Transportation
Competant Authority for the United States

CLASSIFICATION OF EXPLOSIVES

Based upon a request by Charles W. Perry, III on behalf of BHT Products, Inc., Rt. 1, P.O. Box 196, Hampton, Arkansas, the following items are classed in accordance with Section 173.56, Title 49, Code of Federal Regulations (49 CFR).

U.N. PROPER SHIPPING NAME AND NUMBER: Flammable solids, n.o.s., UN1325

U.N. CLASSIFICATION CODE: 4.1

<u>REFERENCE NUMBER</u>	<u>PRODUCT DESIGNATION/PART NUMBER</u>
EX-8703326	757/850
EX-8703327	758/013
EX-9003405	759/107

*** The following is provided to facilitate transition to the UN system ***

Classification under Sections 173.86 or 173.114a (49 CFR):

DOT DESCRIPTION/COMMERCIAL NAME: Flammable solid, n.o.s.

DOT HAZARD CLASSIFICATION: Flammable solid

U.N. PROPER SHIPPING NAME AND NUMBER: Igniters, UN0325

U.N. CLASSIFICATION CODE: 1.4G

<u>REFERENCE NUMBER</u>	<u>PRODUCT DESIGNATION/PART NUMBER</u>
EX-8703324	756/292 (437-44-2100)

*** The following is provided to facilitate transition to the UN system ***

Classification under Sections 173.86 or 173.114a (49 CFR):

DOT DESCRIPTION/COMMERCIAL NAME: Igniter

DOT HAZARD CLASSIFICATION: Class C explosive

Perry, III, BHT Products, Inc.

U.N. PROPER SHIPPING NAME AND NUMBER: Igniters, UN0454

U.N. CLASSIFICATION CODE: 1.45

<u>REFERENCE NUMBER</u>	<u>PRODUCT DESIGNATION/PART NUMBER</u>
EX-8703325	757/873 (437-43-1000)

*** The following is provided to facilitate transition to the UN system ***

Classification under Sections 173.86 or 173.114a (49 CFR):

DOT DESCRIPTION/COMMERCIAL NAME: Explosive power device, Class C

DOT HAZARD CLASSIFICATION: Class C explosive

Approved by:

for Christine E. Whelton
Alan I. Roberts
Associate Administrator
for Hazardous Materials Safety

JUN 18 1992
(DATE)

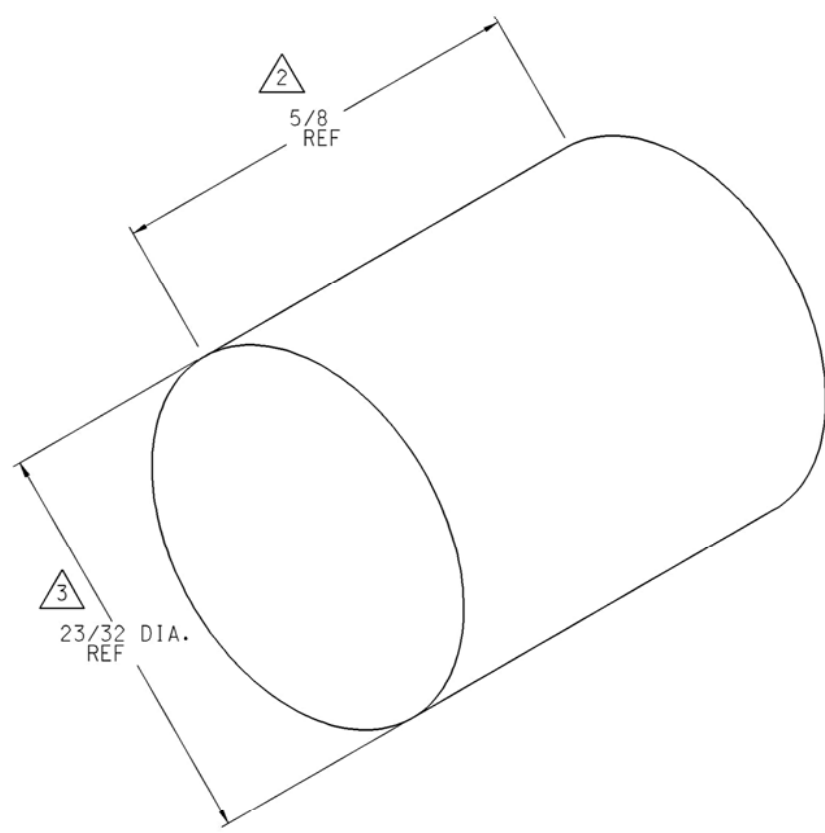

WEIGHT: 9.70 GRAMS
BAKER SECONDARY POWDER

1
2
3
4
5
6
7
8
9
10
11
12
13
14
15
16
17
18
19
20
21
22
23
24
25
26
27
28
29
30
31
32
33
34
35

MATERIAL: BMS		POLYMER/WELDING SPEC:			HEAT TREAT: BHS			COATING: BCS			REF DWG:			CATEGORY: 3F2-1		
DATE	REV	REVISION DESCRIPTION	BY	CHK	APP	DATE	REV	REVISION DESCRIPTION	BY	CHK	APP					
						05-11-04	A 3	WAS 5/8	JFC	MWW	JHK					
						05-11-04	A 2	WAS 23/32	JFC	MWW	JHK					
						01-12-01	A 1	REDRAWN ON MICROSTATION FOR CLARITY	CJM	NMD	JHK					

TOLERANCES FOR MACHINED SURFACES UNLESS OTHERWISE SPECIFIED
 .X - ± .06
 .XX - ± .03
 .XXX - ± .015
 * ± .2

CONCENTRICITY .015 TIR
 INSIDE CORNERS .03-.06 R
 REMOVE ALL BURRS
 BREAK ALL EDGES TO .015-.030 (RAD. OR 45°)
 SURFACE FINISH √250 MAX. THREADS √175 MAX

ALL ANGLES TO BE 25°-50°
 ALL DIMENSIONS ARE IN INCHES
 CHECK HARDNESS AT STAMPED PRODUCT NUMBER LOCATION

TITLE
**SHIPPING DRAWING
 FOR SECONDARY IGNITER**

MATERIAL:
 (REF.)

SUPERSEDES	DATE	DRAWING NO.	PAGE
	01-12-01	757	1
MATERIAL NO.	PRODUCT FAMILY		OF
H437431000	H43743	873-00	3
DRAWN BY:	CHECKED	APPROVED	
C MURRAY	NMD	JHK	
© 2004 BAKER OIL TOOLS DIVISION OF BAKER HUGHES INCORPORATED THIS DOCUMENT (TOGETHER WITH THE INFORMATION THEREON) IS THE PROPERTY OF BAKER HUGHES INCORPORATED. (BAKER) IS CONFIDENTIAL AND IS AN UNPUBLISHED WORK. WITH ALL RIGHTS RESERVED TO BAKER. THIS DOCUMENT IS SUBJECT TO RETURN ON DEMAND. IT MAY NOT BE COPIED OR REPRODUCED IN WHOLE OR IN PART WITHOUT THE EXPRESS WRITTEN CONSENT OF BAKER. IT MAY NOT BE USED DIRECTLY OR INDIRECTLY IN ANY WAY DETRIMENTAL TO BAKER'S INTEREST.			
			Baker Oil Tools



Test Report: N002769
Date of Report: 27 May 2008
Date of Testing: 23 May 2008
Purchase Order Number: 3647

**DEPARTMENT OF TRANSPORTATION
PERFORMANCE ORIENTED PACKAGE TESTING
CERTIFICATION**

Performed by:
National Technical Systems
Highland Industrial Park
Building K-5
Camden, AR 71701
870-574-1335

Testing Performed for:
BHT Products
Route 1 Box 196
Hampton, AR 71744
(870) 798-2486

Re-Qualification Testing of a Single Walled
UN 4G Fiberboard Box

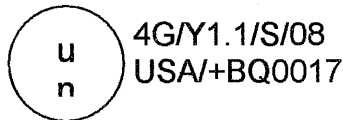

Approved by:  Date: 27 May 08
Eric Loucks, Manager Quality Assurance/Safety

Approved by:  Date: 5-27-08
Shannon Perry, Program Engineer



Explosives Notified Body, Health & Safety Laboratory, Harpur Hill, Buxton, Derbyshire, SK17 9JN, United Kingdom
Tel.: +44 (0)1298 28150 Fax.: +44 (0)1298 28180

EC TYPE EXAMINATION CERTIFICATE

NOTIFIED BODY NO: 0519

CERTIFICATE NO: ENB/P/081/04 Issue 1

- 1. Product Type:** Propellant.
- 2. Product Name:** IGNITERS AND POWER CHARGES as listed in Annex 1 to this certificate.
- 3. Manufacturer's Name and Address:** Baker Oil Tools, BHT Products, Rt. 1 Box 196, Hampton, Arkansas 71744, USA.
- 4. Applicant's Name and Address:** Baker Oil Tools, BHT Products, Rt. 1 Box 196, Hampton, Arkansas 71744, USA.
- 5. Attachments to this Certificate:** Annex 1: products covered by this certificate; Annex 2: list of technical documents examined.

Being a notified body in accordance with the GB Statutory Instrument No 2714 (1993) and Directive 93/15/EEC of 5 April 1993 on the harmonization of the provisions relating to the placing on the market and supervision of explosives for civil uses, the Explosives Notified Body certifies that the above type of product has been examined using Module B of the system for attesting conformity and has been found to conform with the manufacturer's specifications for the type and with the relevant requirements of the Statutory Instrument and the Directive.

A handwritten signature in black ink, reading "R. K. Wharton", with a long horizontal flourish underneath.

Dr R K Wharton
Head, GB Explosives Notified Body

9 February 2004

ANNEX 1 TO EC TYPE EXAMINATION CERTIFICATE ENB/P/081/04 Issue 1

Igniters

H437442200, BP-3S Primary Igniter
H437444200, BP-4S Primary Igniter
H437431000, Secondary Igniter
H437461000, E-12 Igniter

Power Charges

H437665225, #05 Low Temp Slow Set Power Charge
H437660700, #07 Slow Set Power Charge
H437660010, #10 Slow Set Power Charge
H437660020, #20 Slow Set Power Charge
H437660550, #05 Slow Set Power Charge

MATERIAL SAFETY DATA SHEET

1. CHEMICAL PRODUCT AND COMPANY IDENTIFICATION

Manufactured by: BHT PRODUCTS To the specifications of: BAKER OIL TOOLS
RT. 1 BOX 196 HOUSTON, TEXAS
HAMPTON, ARKANSAS 71744
870-798-2486

Emergency Phone Number: Chemtrec: 800-424-9300
Product Name: Secondary Igniter
Product Number: 437-43-1000
Synonyms: Secondary Pellet, Secondary
Formula: Trade Secret

2. COMPOSITION/INFORMATION ON INGREDIENTS

Component	CAS No.	Concentration (%)
Barium Chromate	10294-40-3	84.4
Trade Secret Ingredients	Not Applicable	15.6

3. HAZARDS IDENTIFICATION

Emergency Overview : Danger! Contains Barium Chromate. Human Carcinogen. Do not scrape, crush, break, or pulverize pellets without using appropriate PPE. Do not generate dust!
Potential Health Effects: Can cause cancer. Signs of exposure include vomiting, violent diarrhea, abdominal pain, difficulty in breathing, slow pulse and irregular heart beat. Possible liver damage.
Eye: Irritant, may cause burns.
Skin: Irritant, may cause burns.
Ingestion: Poisonous, ingestion may affect the blood, central nervous system, liver and kidneys.
Inhalation: Component is an irritant to mucous membranes and may cause bleeding and ulceration of nasal septum, sore throat, and coughing.

Medical Conditions Aggravated by Exposure: Large doses may cause cardiac and respiratory failure and hemorrhages in the gastrointestinal tract and kidneys. Cases of pulmonary fibrosis and emphysema may result from prolonged inhalation of component dust. Asthma and other respiratory problems may become aggravated by component. Skin rash may also become aggravated upon exposure.

4. FIRST AID MEASURES

First Aid Procedures: Remove victim from exposure area. Remove contaminated clothing and shoes. Wash affected area with soap and water. Obtain medical attention.
Eye: Flush eyes with running water for 15 minutes. Contact physician.
Skin: Flush affected area with water, wash thoroughly with soap and water.
Ingestion: Induce vomiting. Contact physician.

MATERIAL SAFETY DATA SHEET

Inhalation: Remove to fresh air. Have victim blow nose to remove substance, but discourage sniffing. Contact physician.

Note to physicians: Remove chromates by gastric lavage.

5. FIRE FIGHTING MEASURES

Flash Point: Not applicable.	Method: Flood with water.
Autoignition Temperature: >600°F	

Flammability Limits in Air: Contains oxidizer and fuel, does not require air for combustion.	
Lower Explosive Limit (LEL): Not applicable, will not detonate.	Upper Explosive Limit (UEL): Not applicable, will not detonate.

NFPA Classification	
Health: Not Rated	Reactivity: Not Rated
Fire: Not Rated	Specific Hazard: Not Rated

Extinguishing Media: Flood with water to cool fire and hinder propagation.	
Flammable Properties: Contains oxidizer and fuel. Does not require air for combustion.	Firefighting Instructions: Use unmanned water hose and withdraw from area until fire is out. If manned entrance is required, wear full protective clothing and NIOSH approved self-contained breathing apparatus with full facepiece operated in the pressure demand or other positive pressure mode.
Hazardous Combustion: Will produce toxic fumes (fumes may be carcinogenic).	Unusual Fire and Explosion Hazards: Combustion generates extreme heat and hot particles.

6. ACCIDENTAL RELEASE MEASURES

Spill Information: Evacuate spill area until dust settles or appropriate PPE can be obtained. Do not touch or walk through spilled material. Keep ignition sources and flammable materials away from spilled material. Do not smoke. Keep material dry. If wet, absorb liquid with sand or other non-combustible material. Sweep or scoop up material into a clean, dry container and cover loosely. Move container to hazardous waste storage area and label properly. Do not use water to clean up spills or porous or wood surfaces (surface may become impregnated with material).

7. HANDLING AND STORAGE

Handling: Keep away from heat, ignition sources and flammable materials. No smoking, open sparks or open flame in area.

Storage: Store in dry area away from heat, ignition sources and flammable materials. Keep in closed, original shipping containers or approved magazine.

MATERIAL SAFETY DATA SHEET

8. EXPOSURE CONTROLS/PERSONAL PROTECTION

Engineering Controls: If handled in a confined area, insure adequate ventilation to prevent inhalation of dust.
Personal Protective Equipment: During normal use, this material may generate dust; proper PPE must be used to minimize exposure.
Respiratory: Use NIOSH approved high efficient particulate respirator (HEPA filter) if dust is present or being generated.
Skin: Wear general purpose protective clothing and gloves to prevent contact.
Eye: Dust resistant safety goggles. Have eye-wash station available within immediate work area for emergency use.

EXPOSURE GUIDELINES	
COMPOUND	RECOMMENDED EXPOSURE LIMIT
	TWA
Soluble Barium compounds	0.5 mg/m ³
0.5 mg/m ³ = milligrams per cubic meter	

9. PHYSICAL AND CHEMICAL PROPERTIES

Molecular Weight: 255.36 (MW of primary component)	Ph: No applicable information available.
Boiling Point: No applicable information available	Specific Gravity: Not applicable
Melting Point: No applicable information available.	Vapor Pressure: Negligible
Vapor Density (air = 1): No applicable information available.	Percent Volatile: No applicable information available.
Solubility in Water: Insoluble	Physical State: Solid compressed powder pellet
Appearance and Odor: Gray to dark green pellet. No odor.	Density: Not applicable

10. STABILITY AND REACTIVITY

Stability: Product contains oxidizing and reducing agents and is potentially unstable.	Hazardous Polymerization: Will not occur.
Incompatibility: None known	Hazardous Reactions/Decomposition: Ignites at high temperatures.
Conditions to Avoid: Extreme heat, generation of dust.	

11. TOXICOLOGICAL INFORMATION

Target Organs: Lungs, CNS, liver kidneys and blood.	Primary Routes of Entry: Inhalation or ingestion.		
Product listed as a Carcinogen or Potential Carcinogen by			
NTP: No	IARC: Yes	OSHA: No	Other: No

MATERIAL SAFETY DATA SHEET

Component Toxicity

Considered a poison and a human carcinogen.

12. ECOLOGICAL INFORMATION

No applicable information available.

13. DISPOSAL CONSIDERATIONS

Dispose of product in a manner consistent with applicable regulations. Contact local environmental or health authorities for approved disposal of explosive materials. Observe federal, state and local laws. Contaminated residue, combustion by products and sweepings are considered hazardous waste.

RCRA Hazard Class: No applicable information available.

14. TRANSPORT INFORMATION

DOT (Department of Transportation)

Proper Shipping Name: Igniters

Hazard Class: 1.4S Explosive

Identification Number: UN0454

Packing Group: II

ECCN: 1C992

15. REGULATORY INFORMATION

TSCA Components of this product are listed on the TSCA Inventory.

CERCLA No applicable information available.

SARA TITLE III

Reportable Quantity: (The reportable quantity for mixtures is based on the component with the lowest reportable quantity and its percentage in the product.)

500,000 lbs.

Section 302/304 Extremely Hazardous Substances: None

Section 313 Toxic Chemicals: Barium Compounds 84.4%

16. OTHER INFORMATION

This product is designed for use exclusively in Baker Oil Tools equipment. It must be handled only in strict compliance with published Baker Oil Tools procedures. Use of this product in other

MATERIAL SAFETY DATA SHEET

equipment or in any manner inconsistent with Baker Oil Tools published procedures may result in damage to property or personal injury. BAKER OIL TOOLS EXPRESSLY LIMITS ITS WARRANTY AND ALL OTHER RESPONSIBILITY FOR ITS PRODUCT TO USES AND FOR HANDLING CONSISTENT WITH BAKER OIL TOOLS PUBLISHED PROCEDURES.

DISCLAIMER

The information, recommendations and suggestions herein were compiled from reference material and other sources believed to be reliable. However, the MSDS's accuracy or completeness is not guaranteed by BHT Products, or its affiliates, nor is any responsibility assumed or implied for any loss or damage resulting from inaccuracies or omissions. Since conditions of use are beyond our control, no warranties of merchantability or fitness for a particular purpose are expressed or implied. This MSDS is not intended as a license to operate under, or recommendation to infringe on, any patents. Appropriate warning and safe handling procedures should be provided to handlers and users.

Prepared By: Eagle Environmental Health, Inc.
4151 Southwest Freeway, Suite 410
Houston, Texas 77027

July 19, 1995

Reviewed by: BHT Products
Rt 1 Box 196
Hampton, Arkansas 71744

March 9, 1999

August 7, 2003

January 1, 2006