

Shaped Charge Summary

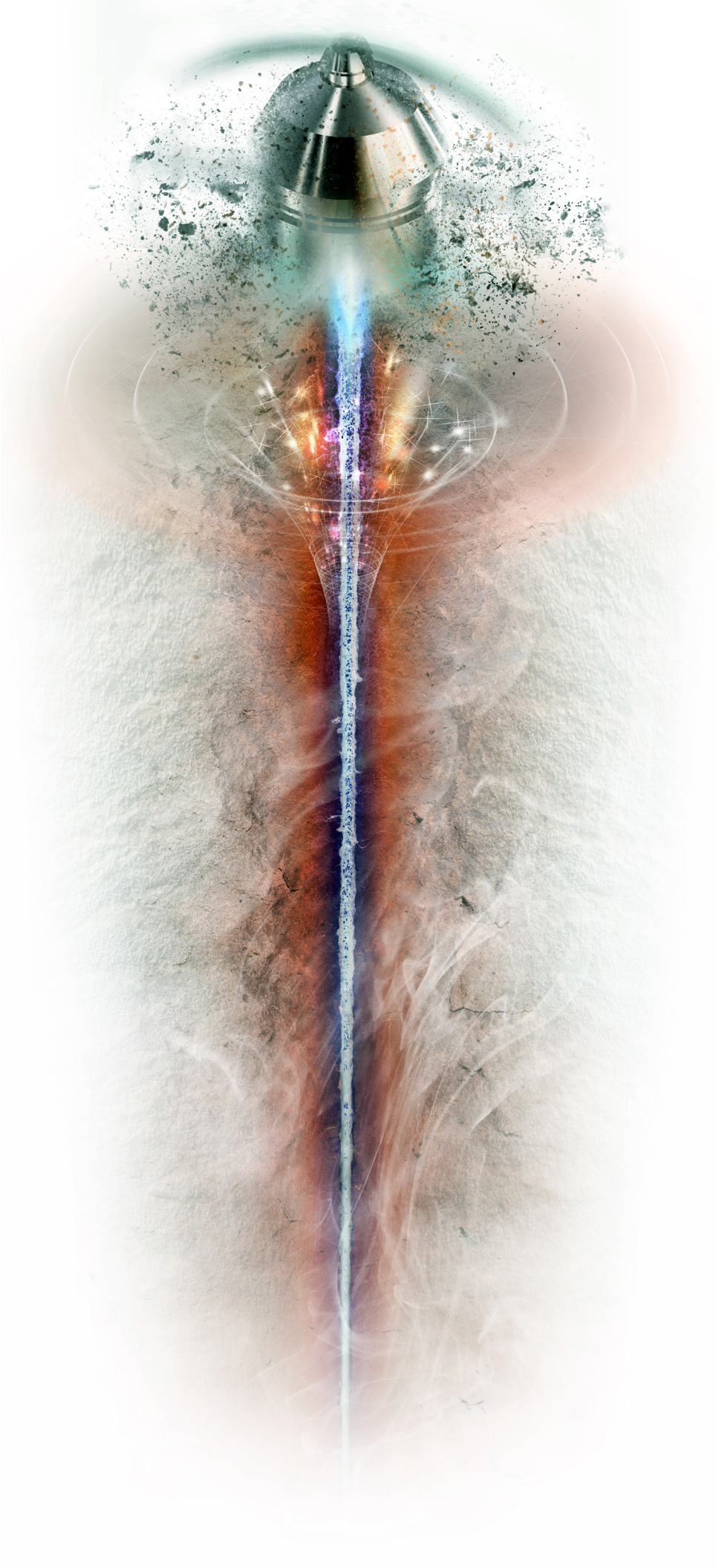

Shaped Charges for
every application



More From Hunting

www.hunting-intl.com/titan

Hunting Detonating Cord

Hunting Detonating Cord is designed for use in any perforating system. Both RDX and HMX products have been successfully deployed in downhole service applications within appropriate operating ranges (reference time and temperature chart). Hunting detonating cord was designed for optimal output and sensitivity to ensure reliable transfer between initiator and cord.

Time - Temperature Chart

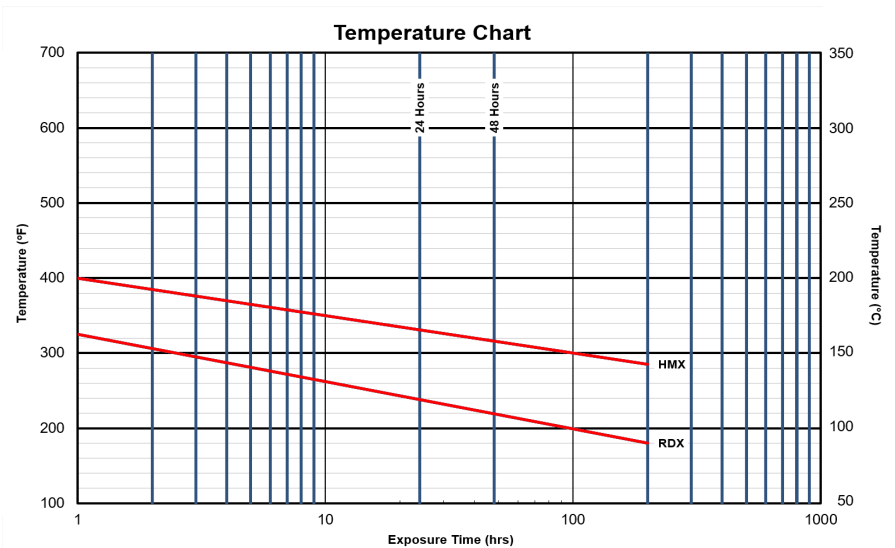
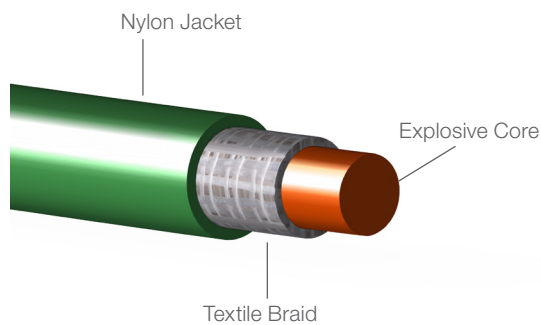

Specs

Cord Type	Cord Color	Part Number	International Air Pack Part No.	Explosive Core Load (gr/ft)		Diameter (in)			Detonation Velocity (m/s)	Jacket Thickness (in)	Shrinkage (at 325°F)
				Nominal	Min	Nominal	Min	Max			
80 Gr RDX	Blue	CORD-80RDX-T	CORD-80RDX-AIR-T*	80 (17.00 g/m)	75 (15.96 g/m)	0.210 (5.33mm)	0.202 (5.13mm)	0.218 (5.54mm)	6,800 (22,309 ft/s)	0.008 (0.20mm)	6%
80 Gr RDX LS	Blue	CORD-80RDX-LS-T	CORD-80RDX-LS-AIR-T*	80 (17.00 g/m)	75 (15.96 g/m)	0.210 (5.33mm)	0.202 (5.13mm)	0.218 (5.54mm)	6,800 (22,309 ft/s)	0.008 (0.20mm)	1%
80 Gr RDX LS XHV	Blue	CORD-80RDX-LS-XHV-T*	CORD-80RDX-LS-XHV-AIR-T*	80 (17.00 g/m)	75 (15.96 g/m)	0.210 (5.33mm)	0.202 (5.13mm)	0.218 (5.54mm)	7,500 (24,606 ft/s)	0.008 (0.20mm)	1%
80 Gr HMX	Green	CORD-80HMX-T	CORD-80HMX-AIR-T*	80 (17.00 g/m)	75 (15.96 g/m)	0.210 (5.33mm)	0.202 (5.13mm)	0.218 (5.54mm)	6,800 (22,309 ft/s)	0.008 (0.20mm)	6%
80 Gr HMX LS	Green	CORD-80HMX-LS-T	CORD-80HMX-LS-AIR-T*	80 (17.00 g/m)	75 (15.96 g/m)	0.210 (5.33mm)	0.202 (5.13mm)	0.218 (5.54mm)	6,800 (22,309 ft/s)	0.008 (0.20mm)	1%
80 Gr HMX LS XHV	Green	CORD-80HMX-LS-XHV-T*	CORD-80HMX-LS-XHV-AIR-T*	80 (17.00 g/m)	75 (15.96 g/m)	0.210 (5.33mm)	0.202 (5.13mm)	0.218 (5.54mm)	7,500 (24,606 ft/s)	0.008 (0.20mm)	1%

Temperature resistance is based upon the manufacturer's laboratory tests in air, at ambient pressure only. **Shrinkage** is defined in overall decrease in length.

Velocity was tested unconfined at ambient pressure.

*Coming Soon: contact your sales representative for field trial opportunities.

Shaped Charge Summary

www.hunting-intl.com/titan

Hunting's shaped charges and perforating guns are engineered to exact specifications and achieve **Optimum** performance when used as part of Hunting's Complete Perforating System

All charges available in RDX, HMX and HNS explosive type unless otherwise specified. Systems available in other SPF/Phasing configurations.

For GunFacts® visit us at:

www.hunting-intl.com/titan/perforating-guns-and-setting-tools

For API Shaped Charge Certificates visit us at:

www.hunting-intl.com/titan/energetics/api-shaped-charge-performance-certification

Table of Contents

Page Number	Contents
1	Shaped Charge Lines
	Time Temperature Chart
	Charge Type Abbreviation Key
2	EQUAfrac Consistent Hole Shaped Charges
	EQUAfrac OP Oriented Perforating Shaped Charges
3	EQUAfrac Limited: Super-Consistent, Limited Penetration Shaped Charges
4	Perfecta Rock Charges
	HYPERfecta (HSX) Ultra-High Temperature Shaped Charges
	Capsule Gun Systems
	Retreiveable Gun Systems
5	Expendable Gun Systems: 2-3/4 inch - 4 inch
6	Expendable Gun Systems: 4-1/2 inch - 7 inch
	Recomplete Shaped Charges
7	Ported Casing (PPG)
	Economical Expendable (EEG) Gun System Shaped Charges
	Knockout Puncher and Circulation Charges
8	Hunting Shaped Charge Part Numbering System

Shaped Charge Lines

www.hunting-intl.com/titan

Perfecta® Shaped Charges

Superior performance in all types of formations. With a wide variety of SDP, GH, and BH shaped charges available to meet your specific needs. PERFECTA shaped charges can be deployed using any conveyance methodology.

Perfecta® Rock Charges

Superior performance, Super Deep Penetrating shaped charges tested in stressed-rock to accurately mimic real-world conditions. Perfecta® Rock Charges can be deployed using any conveyance methodology.

EQUAfrac® Shaped Charges

EQUAfrac® shaped charges are the ideal solution for obtaining consistent hole size, optimal penetration and minimal debris in horizontal completions.

EQUAfrac® Limited Shaped Charges

EQUAfrac® Limited shaped charges are super consistent shaped charges for applications where limited penetration is necessary.

EQUAfrac® OP Shaped Charges

EQUAfrac® OP shaped charges are super consistent shaped charges for oriented perforating applications where all shaped charges are firing in the same direction or “phase”.

HYPERfecta® Shaped Charges

Proprietary HSX explosive is used to make charges with high performance at ultra-high temperatures, without the use of HNS or HMX.

KnockOut® Shaped Charges

Unprecedented design for reduced penetration circulation/puncher charges. These charges minimize collateral impact on the secondary casing string while maximizing hole size in the target casing.

Recomplete Shaped Charges

These charges fit 2-1/2” guns and are manufactured and rigorously tested to perform well when perforating through both liner and casing.

Time - Temperature Chart

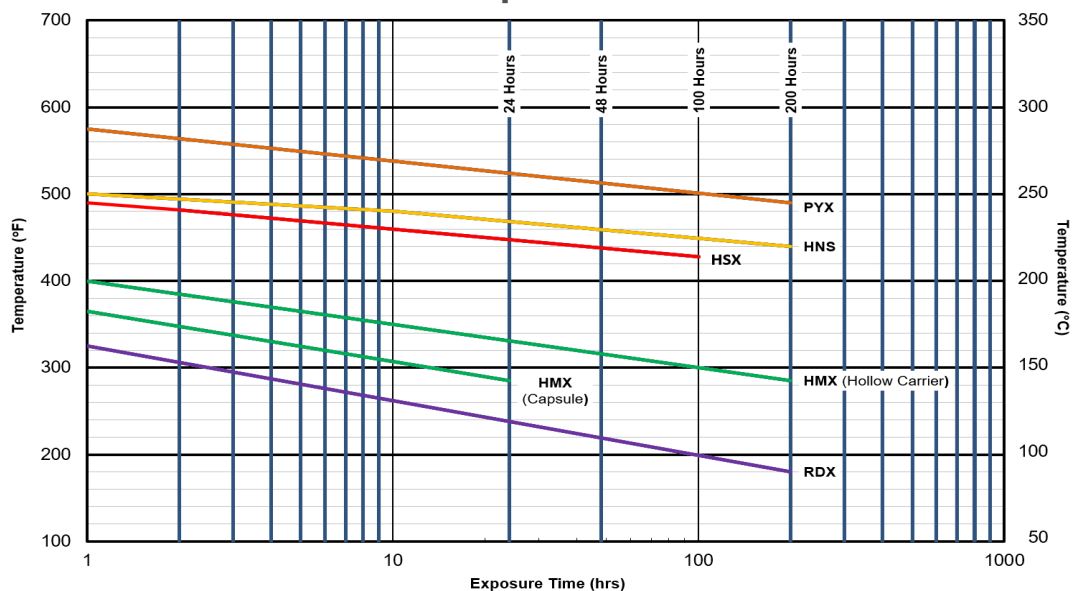

Charge Type Abbreviation Key

- | | |
|-------------------------------------|-----------------------------|
| DP = Deep Penetrating Charge | SBH = Super Big Hole Charge |
| SDP = Super Deep Penetrating Charge | CH = Consistent Hole |
| GH = Good Hole Charge | SCH = Super Consistent Hole |
| BH = Big Hole Charge | |

EQUAfrac® Consistent Hole Shaped Charges

Shaped Charge Information						Shaped Charge Performance				
Gun O.D. (in) [mm]	Charge Part Number	Type	Target Type	Exp. Type	Exp. Weight (g)	Shot Density (SPF) [SPM] Phasing	Avg. Entry Hole (in) [mm]	Decentralized EHD Variation	Penetration (in) [cm]	Data Type
2-1/2 [64]	RTG-2512-371T	CH	4-1/2 inch OD, 13.5#, P-110	RDX	12	6 [20] 60°	0.29 [7.62]	7.3%	21.3 [54.10]	Gun/QC Spec
	RTG-2512-371T	CH	5-1/2 inch OD, 23#, P-110	RDX	12	6 [20] 60°	0.32 [8.13]	5.9%	21.3 [54.10]	Gun/QC Spec
2-3/4 [70]	EXP-2716-371T	CH	4-1/2 inch OD, 13.5#, P-110	RDX	16	6 [20] 60°	0.32 [8.13]	6.4%	25.8 [65.51]	API RP-19B
	EXP-2716-372T	CH	4-1/2 inch OD, 11.6#, L-80	RDX	16	6 [20] 60°	0.34 [8.64]	2.9%	14.0 [35.56]	API RP-19B
	EXP-2716-372T	CH	5-1/2 inch OD, 20#, P-110	RDX	16	6 [20] 60°	0.32 [8.13]	8.6%	16.6 [42.16]	Gun/QC Spec
	EXP-2816-371T*	CH	5-1/2 inch OD, 23#, P-110	RDX	16	6 [20] 60°	0.25 [6.35]	7.0%	27.6 [70.10]	Gun/QC Spec
3-1/8 [79]	EXP-3321-372T	CH	5-1/2 inch . OD, 20#, P-110	RDX	21	6 [20] 60°	0.32 [8.13]	2.5%	34.3 [87.12]	Gun/QC Spec
	EXP-3323-471T	CH	4-1/2 inch OD, 13.5#, P-110	HMX	23	6 [20] 60°	0.39 [9.91]	3.6%	24.8 [62.87]	API RP-19B
	EXP-3323-371T	CH	5-1/2 inch OD, 23#, P-110	RDX	23	6 [20] 60°	0.35 [8.89]	8.9%	32.4 [82.30]	Gun/QC Spec
	EXP-3323-373T	CH	5-1/2 inch OD, 20#, P-110	RDX	23	6 [20] 60°	0.41 [10.2]	7.6%	26.1 [66.29]	Gun/QC Spec
	EXP-3323-373T	CH	5-1/2 inch OD, 23#, P-110	RDX	23	6 [20] 60°	0.40 [10.2]	3.3%	26.1 [66.29]	Gun/QC Spec
	EXP-3323-471T	CH	4-1/2 inch OD, 11.6#, L-80	HMX	23	6 [20] 60°	0.42 [10.67]	2.0%	24.6 [62.48]	API RP-19B
3-3/8 [86]	EXP-3323-471T	CH	5-1/2 inch OD, 23#, P-110	HMX	23	6 [20] 60°	0.38 [9.65]	4.9%	31.6 [80.26]	API RP-19B
	EXP-3326-371T	CH	4-1/2 inch OD, 11.6#, L-80	RDX	26	6 [20] 60°	0.47 [11.94]	4.1%	34.7 [88.13]	API RP-19B
	EXP-3326-371T	CH	5-1/2 inch OD, 23#, P-110	RDX	26	6 [20] 60°	0.44 [11.18]	4.5%	35.6 [90.42]	API RP-19B
	EXP-3326-371T	CH	6 inch OD, 24.5#, P-110	RDX	26	6 [20] 60°	0.44 [11.18]	7.2%	30.7 [77.98]	Gun/QC Spec

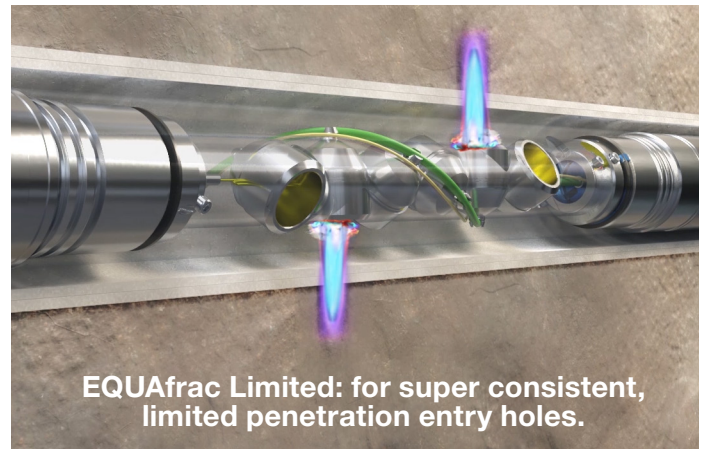
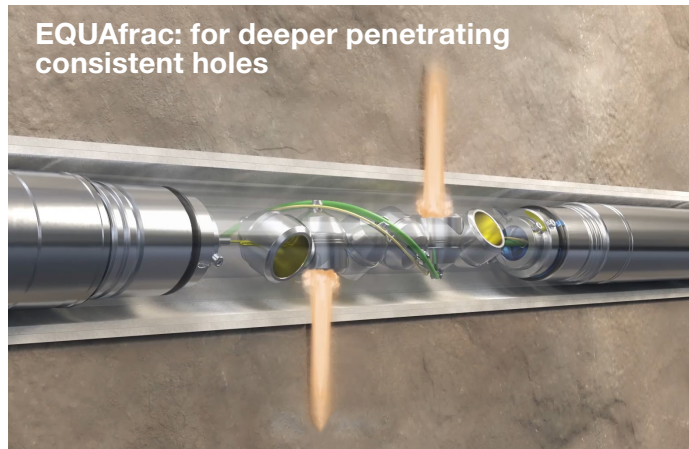

EQUAfrac® OP: Super-Consistent, Oriented Perforating

Orientation	Gun O.D. (in) [mm]	Charge Part Number	Type	Target Type	Exp.	Exp. Type	Shot Density (SPF) [SPM] Phasing	Average Entry Hole (in) [mm]	Entry Hole Range (in)[mm]	Decentralized EHD Variation	Penetration (in)[cm]	Test Type
0°	3-1/8 [79]	SCH-3118-381	SCH	5-1/2 inch OD, 20#, P110	18	RDX	4 [13.3] 0°	0.34 [8.63]	0.33-0.35 [8.38-8.89]	3.5%	7.5 [19.05]	Gun/QC Spec
		SCH-3118-381	SCH	5-1/2 inch OD, 23#, P110	18	RDX	4 [13.3] 0°	0.34 [8.63]	0.33-0.35 [8.38-8.89]	2.2%	7.5 [19.05]	Gun/QC Spec
		SCH-3121-381	SCH	5-1/2 inch OD, 20#, P110	21	RDX	4 [13.3] 0°	0.39 [9.90]	0.39-0.40 [9.90-10.16]	1.0%	7.5 [19.05]	Gun/QC Spec
		SCH-3121-381	SCH	5-1/2 inch OD, 23#, P110	21	RDX	4 [13.3] 0°	0.40 [10.16]	0.39-0.40 [9.90-10.16]	1.8%	7.5 [19.05]	Gun/QC Spec
		SCH-3123-381	SCH	5-1/2 inch OD, 20#, P110	23	RDX	4 [13.3] 0°	0.45 [11.43]	0.44-0.46 [11.17-11.68]	2.0%	7.5 [19.05]	Gun/QC Spec
		SCH-3123-381	SCH	5-1/2 inch OD, 23#, P110	23	RDX	4 [13.3] 0°	0.45 [11.43]	0.44-0.46 [11.17-11.68]	1.9%	7.5 [19.05]	Gun/QC Spec
		SCH-3123-382	SCH	5-1/2 inch OD, 20#, P110	23	RDX	4 [13.3] 0°	0.51 [12.95]	0.50-0.52 [12.70-13.21]	1.5%	7.5 [19.05]	Gun/QC Spec
		SCH-3123-382	SCH	5-1/2 inch OD, 23#, P110	23	RDX	4 [13.3] 0°	0.51 [12.95]	0.50-0.51 [12.70-12.95]	1.2%	7.5 [19.05]	Gun/QC Spec
3-3/8 [86]	3-3/8 [86]	SCH-3323-381	SCH	5-1/2 inch OD, 20#, P110	23	RDX	4 [13.3] 0°	0.54 [13.72]	0.52-0.56 [13.21-14.22]	2.7%	7.5 [19.05]	Gun/QC Spec
		SCH-3323-381	SCH	5-1/2 inch OD, 23#, P110	23	RDX	4 [13.3] 0°	0.55 [13.97]	0.54-0.56 [13.72-14.22]	1.9%	7.5 [19.05]	Gun/QC Spec

EQUAfrac® Limited: Super-Consistent, Limited Penetration Shaped Charges

Shaped Charge Information						Shaped Charge Performance					
Gun O.D. (in) [mm]	Charge Part Number	Type	Target Type	Exp. Type	Exp. Weight (g)	Shot Density (SPF) [SPM] Phasing	Avg. Entry Hole (in) [mm]	Entry Hole Range (in)[mm]	Decentralized EHD Variation	Penetration (in)[cm]	Test Type
2-3/4 [70]	SCH-2713-371	SCH	4-1/2 Inch OD, 13.5#, P110	RDX	13	6 [20] 60°	0.30 [7.62]	0.29-0.33 [7.37-8.38]	4.6%	5.5 [13.97]	Gun/QC Spec
	SCH-2715-371	SCH	4-1/2 Inch OD, 13.5#, P110	RDX	15	6 [20] 60°	0.35 [8.89]	0.34-0.37 [8.63-9.39]	2.1%	6.5 [16.51]	Gun/QC Spec
	SCH-2717-371	SCH	4-1/2 inch OD, 13.5#, P110	RDX	17	6 [20] 60°	0.41 [10.41]	0.39-0.44 [9.90-11.17]	3.9%	6.5 [19.05]	Gun/QC Spec
3-1/8 [79]	SCH-3113-372	SCH	4-1/2 Inch OD, 13.5#, P110	RDX	13	6 [20] 60°	0.27 [6.86]	0.25-0.29 [6.35-7.37]	4.8%	6.5 [16.51]	Gun/QC Spec
	SCH-3113-372	SCH	5-1/2 Inch OD, 20#, P110	RDX	13	6 [20] 60°	0.26 [6.60]	0.25-0.29 [6.35-7.37]	5.2%	6.5 [16.51]	Gun/QC Spec
	SCH-3113-371	SCH	4-1/2 inch OD, 13.5#, P110	RDX	13	6 [20] 60°	0.30 [7.62]	0.28-0.32 [7.11-8.13]	4.3%	5.5 [13.97]	Gun/QC Spec
	SCH-3113-371	SCH	5-1/2 inch OD, 20#, P110	RDX	13	6 [20] 60°	0.31 [7.87]	0.29-0.33 [7.37-8.38]	4.0%	5.5 [13.97]	Gun/QC Spec
	SCH-3113-371	SCH	5-1/2 inch OD, 23#, P110	RDX	13	6 [20] 60°	0.32 [8.13]	0.29-0.35 [7.37-8.89]	5.4%	5.5 [13.97]	Gun/QC Spec
	SCH-3113-372	SCH	5-1/2 Inch OD, 23#, P110	RDX	13	6 [20] 60°	0.26 [6.60]	0.24-0.28 [6.10-7.11]	4.4%	6.5 [16.51]	Gun/QC Spec
	SCH-3118-372	SCH	5-1/2 inch OD, 23#, P110	RDX	18	6 [20] 60°	0.35 [8.89]	0.34-0.37 [8.63-9.39]	2.3%	7.5 [19.05]	Gun/QC Spec
	SCH-3118-371	SCH	4-1/2 inch OD, 13.5#, P110	RDX	18	6 [20] 60°	0.35 [8.89]	0.34-0.37 [8.63-9.39]	2.6%	7.5 [19.05]	Gun/QC Spec
	SCH-3118-371	SCH	5 inch OD, 18#, P110	RDX	18	6 [20] 60°	0.37 [9.39]	0.33-0.40 [8.38-10.16]	4.8%	7.5 [19.05]	Gun/QC Spec
	SCH-3118-371	SCH	5-1/2 inch OD, 20#, P110	RDX	18	6 [20] 60°	0.38 [9.65]	0.35-0.40 [8.89-10.16]	5.3%	7.5 [19.05]	Gun/QC Spec
	SCH-3118-371	SCH	5-1/2 inch OD, 23#, P110	RDX	18	6 [20] 60°	0.37 [9.39]	0.35-0.40 [8.89-10.16]	5.2%	7.5 [19.05]	Gun/QC Spec
	SCH-3121-371	SCH	4-1/2 inch OD, 13.5#, P110	RDX	21	6 [20] 60°	0.39 [9.90]	0.38-0.40 [9.65-10.16]	2.5%	7.5 [19.05]	Gun/QC Spec
	SCH-3121-371	SCH	5 inch OD, 18#, P110	RDX	21	6 [20] 60°	0.42 [10.66]	0.40-0.46 [10.16-11.68]	3.8%	7.5 [19.05]	Gun/QC Spec
	SCH-3121-371	SCH	5-1/2 inch OD, 20#, P110	RDX	21	6 [20] 60°	0.42 [10.66]	0.39-0.45 [9.90-11.43]	4.2%	7.5 [19.05]	Gun/QC Spec
	SCH-3121-371	SCH	5-1/2 inch OD, 23#, P110	RDX	21	6 [20] 60°	0.41 [10.41]	0.38-0.44 [9.65-11.17]	4.7%	7.5 [19.05]	Gun/QC Spec
	SCH-3121-371	SCH	6 inch OD, 24.5#, P110	RDX	21	6 [20] 60°	0.41 [10.41]	0.39-0.45 [9.90-11.43]	5.1%	7.5 [19.05]	Gun/QC Spec
	SCH-3123-372	SCH	5-1/2 inch OD, 20#, P110	RDX	23	6 [20] 60°	0.48 [12.19]	0.45-0.51 [11.43-12.95]	3.3%	7.5 [19.05]	Gun/QC Spec
	SCH-3123-372	SCH	5-1/2 inch OD, 23#, P110	RDX	23	6 [20] 60°	0.47 [11.94]	0.45-0.51 [11.43-12.95]	4.0%	7.5 [19.05]	Gun/QC Spec
SCH-3123-371	SCH	5-1/2 inch OD, 20#, P110	RDX	23	6 [20] 60°	0.53 [13.46]	0.46-0.59 [11.68-14.99]	7.7%	8.0 [20.32]	Gun/QC Spec	

Note: EQUAfrac and EQUAfrac Limited charges are available in H-Lok™ versions for the H-1 Perforating System®. Add "-H1" to the partnumber, example: EXP-3323-471T-H1
 *Requires special gun assembly part number 0363-E0L-066, all others compatible with standard Hunting perforating gun assemblies.

Perfecta® Rock Charges: Super Deep Penetration Shaped Charges, Tested in Stressed Rock

Shaped Charge Information					API RP 19B Section 2 Testing Performance					
Gun OD (in)[mm]	Charge Part Number	Type	Exp. Type	Exp. Weight (g)	1,500 psi		5,500 psi		9,500 psi	
					Penetration (in)[cm]	Entry Hole (in)[mm]	Penetration (in)[cm]	Entry Hole (in)[mm]	Penetration (in)[cm]	Entry Hole (in)[mm]
2 [50]	RTG-2107-422T	HMX	SDP	7	9.4 [23.88]	0.18 [4.6]	9.8 [24.89]	0.19 [4.8]	5.0 [12.70]	0.19 [4.8]
2-7/8 [73]	EXP-2818-422T	HMX	SDP	18	17.9 [45.47]	0.32 [8.1]	15.7 [39.88]	0.31 [7.9]	12.8 [32.51]	0.32 [8.1]
3-3/8 [86]	EXP-3326-422T	HMX	SDP	26	18.8 [47.75]	0.44 [11.2]	16.0 [40.64]	0.43 [10.9]	14.4 [36.58]	0.43 [10.9]
4-1/2 [114]	EXP-4545-422T	HMX	SDP	45	25.4 [64.52]	0.42 [10.7]	20.8 [52.83]	0.38 [9.7]	18.9 [48.01]	0.35 [8.9]

Penetration in Berea sandstone with minimum 5700 psi uniaxial compressive strength, and 0-psi pore pressure

HYPERfecta (HSX): Ultra-High Temperature Shaped Charges

Shaped Charge Information					Shaped Charge Performance						
Gun OD (in)[mm]	Charge Part Number†	Type	Exp. Type	Exp. Weight (g)	Shot Density (spf)[spm] Phasing	Casing Size (in)[mm]	Casing Weight (lb/ft)[kg/m]	Target Strength (psi)[MPa]	Entry Hole (in)[mm]	Penetration (in)[cm]	Data Type
2 [51]	EXP-2008-721TB	SDP	HSX	8.0	6 [20], 60°	3-1/2 [88.9]	9.2 [13.7]	9,288 [64.0]	0.32 [8.1]	18.57 [47.17]	QC Spec
3-3/8 [86]	EXP-3327-721TB	SDP	HSX	26.5	6 [20], 60°	5-1/2 [140]	17 [25.3]	6,318 [43.5]	0.34 [8.6]	39.01 [99.09]	QC Spec
4-1/2 [114]	EXP-4542-721TB	SDP	HSX	41.5	5 [16], 60°	7 [178]	32 [47.6]	5,717 [39.4]	0.42 [11]	46.92 [119.18]	QC Spec

Capsule Strip Gun Systems (CAP)

Shaped Charge Information					Shaped Charge Performance					
Gun OD (in)	Compatible Charge Part No.	Type	Exp. Type	Exp. Weight (g)	Tested Gun OD (in) [mm]	Shot Density (spf)[spm] Phasing	Casing OD (in) [mm]	Entry Hole (in) [mm]	Penetration (in) [cm]	Data Type
1-11/16	CAP-1708-421T	SDP	HMX	8.0	1-11/16 [43]	4 [13] 0°	4-1/2 [114]	0.24 [6.10]	20.41 [51.84]	API RP 19B
2-1/8	CAP-2115-420T	SDP	HMX	15.0	2-1/8 [54]	4 [13] 0°	5-1/2 [140]	0.28 [7.11]	34.84 [88.49]	API RP 19B

Retrievable Tubing Gun Systems (RTG)

Shaped Charge Information					Shaped Charge Performance					
Gun OD (in)	Compatible Charge Part No.	Type	Exp. Type	Exp. Weight (g)	Tested Gun OD (in) [mm]	Shot Density (spf) [spm] Phasing	Casing OD (in) [mm]	Entry Hole (in) [mm]	Penetration (in) [cm]	Data Type
1-3/8	RTG-1302-400	DP	HMX	1.8	1-3/8 [35]	4 [13] 0°	4-1/2 [114]	0.17 [4.32]	4.70 [11.94]	API RP-43
1-9/16	RTG-1604-421T	SDP	HMX	3.5	1-9/16 [40]	6 [20] 0°, 60°	2-3/8 [60]	0.20 [5.08]	12.68 [32.21]	API RP 19B
	RTG-1603-300	DP	RDX	3.2	1-9/16 [40]	4 [13] 180°	2-3/8 [60]	0.23 [5.84]	6.62 [16.81]	API RP-43
	RTG-1603-400	DP	HMX	3.2	1-9/16 [40]	6 [20] 60°	2-3/8 [60]	0.23 [5.84]	6.62 [16.81]	API RP-43
	FLO-1603-410	BH	HMX	3.2	1-9/16 [40]	6 [20] 0°	4-1/2 [114]	0.41 [10.41]	3.23 [8.20]	API RP-43
	RTG-2107-421T	SDP	HMX	7	2 [51]	6 [20] 60°	2-7/8 [73]	0.29 [7.37]	26.07 [66.22]	API RP 19B
2	RTG-2106-331	GH	RDX	6.5	2 [51]	4 [13] 60°	2-7/8 [73]	0.36 [9.14]	11.82 [30.02]	API RP-43
2-1/2	RTG-2512-421T	SDP	HMX	12	2-1/2 [64]	6 [20] 60°	3-1/2 [89]	0.33 [8.38]	31.26 [79.40]	API RP 19B
	RTG-2512-431	GH	HMX	12	2-1/2 [64]	6 [20] 60°	3-1/2 [89]	0.45 [11.43]	20.31 [51.99]	API RP 19B
	FLO-2511-310B	BH	RDX	11.0	2-1/2 [64]	4 [13] 0°	4-1/2 [114]	0.59 [14.99]	4.85 [12.32]	API RP-43

Expendable Gun Systems (EXP)

Shaped Charge Information					Shaped Charge Performance					
Gun OD (in)	Compatible Charge Part No.	Type	Exp. Type	Exp. Weight (g)	Tested Gun OD (in) [mm]	Shot Density (spf)[spm] Phasing	Casing OD (in) [mm]	Entry Hole (in) [mm]	Penetration (in) [cm]	Data Type
2-3/4 & 2-7/8	EXP-2716-421T	SDP	HMX	16.0	2-3/4 [70]	6 [20] 60°	4-1/2 [114]	0.38 [9.65]	35.94 [91.29]	API RP 19B
	EXP-2818-421T	SDP	HMX	18.0	2-3/4 [70]	6 [20] 60°	4-1/2 [114]	0.41 [10.41]	36.22 [92.00]	API RP 19B
	EXP-2818-421T	SDP	HMX	18.0	2-7/8 [73]	6 [20] 60°	4-1/2 [114]	0.41 [10.41]	36.22 [92.00]	API RP 19B
	RTG-2512-421T	SDP	HMX	12.0	2-3/4 [70]	6 [20] 60°	4-1/2 [114]	0.36 [9.14]	31.90 [81.03]	API RP 19B
	FLO-2511-310B	BH	RDX	11.0	2-1/2 [64]	4 [13] 0°	4-1/2 [114]	0.59 [14.99]	4.85 [12.32]	API RP-43
	FLO-2715-310B	BH	RDX	15.0	2-3/4 [70]	6 [20] 60°	4-1/2 [114]	0.72 [18.29]	4.67 [11.86]	API RP-43
3-1/8	EXP-3319-423T	SDP	HMX	19.0	3-1/8 [79]	6 [20] 60°	4-1/2 [114]	0.38 [9.65]	45.89 [116.56]	API RP 19B
	EXP-3321-421T	SDP	HMX	21.0	3-1/8 [79]	6 [20] 60°	4-1/2 [114]	0.42 [10.67]	44.19 [112.24]	API RP 19B
	EXP-3323-423T	SDP	HMX	22.7	3-3/8 [86]	6 [20] 60°	4-1/2 [114]	0.46 [11.68]	41.17 [104.57]	API RP 19B
	EXP-3112-421T	DP	HMX	12.0	3-1/8 [79]	12 [39] 135/45°	5 [127]	0.31 [7.87]	19.82 [50.34]	API RP-43
	EXP-3319-302	DP	RDX	19.0	3-3/8 [86]	6 [20] 60°	4-1/2 [114]	0.41 [10.41]	22.04 [55.98]	API RP-43
	EXP-3321-362T	DP	RDX	21.0	3-1/8 [79]	6 [20] 60°	4-1/2 [114]	0.46 [11.68]	29.35 [74.55]	API RP 19B
	EXP-3323-401T	DP	HMX	22.7	3-1/8 [79]	6 [20] 60°	4-1/2 [114]	0.43 [10.92]	23.54 [59.80]	API RP-43
	EXP-3323-302	DP	RDX	22.7	3-3/8 [86]	6 [20] 60°	4-1/2 [114]	0.44 [11.18]	21.25 [53.98]	API RP-43
	EXP-3319-331	GH	RDX	19.0	3-1/8 [79]	6 [20] 60°	4-1/2 [114]	0.55 [13.97]	29.18 [74.12]	API RP 19B
	EXP-3319-431	GH	HMX	19.0	3-1/8 [79]	6 [20] 60°	4-1/2 [114]	0.55 [13.97]	29.18 [74.12]	API RP 19B
	EXP-3321-431	GH	HMX	21.0	3-1/8 [79]	6 [20] 60°	4-1/2 [114]	0.56 [14.22]	29.23 [74.24]	API RP 19B
	EXP-3323-431	GH	HMX	22.7	3-3/8 [86]	6 [20] 60°	4-1/2 [114]	0.59 [14.99]	29.42 [74.73]	API RP 19B
3-3/8	FLO-3323-310B	BH	RDX	22.7	3-3/8 [86]	6 [20] 60°	4-1/2 [114]	0.70 [17.78]	6.18 [15.70]	API RP-43
	EXP-3319-423T	SDP	HMX	19.0	3-1/8 [79]	6 [20] 60°	4-1/2 [114]	0.38 [9.65]	45.89 [116.56]	API RP 19B
	EXP-3321-421T	SDP	HMX	21.0	3-1/8 [79]	6 [20] 60°	4-1/2 [114]	0.42 [10.67]	44.19 [112.24]	API RP 19B
	EXP-3323-423T	SDP	HMX	22.7	3-3/8 [86]	6 [20] 60°	4-1/2 [114]	0.45 [11.43]	42.21 [107.21]	API RP 19B
	EXP-3326-421T	SDP	HMX	26.0	3-3/8 [86]	6 [20] 60°	4-1/2 [114]	0.41 [10.41]	50.05 [127.13]	API RP 19B
	EXP-3112-421T	DP	HMX	12.0	3-1/8 [79]	12 [39] 135/45°	5 [127]	0.31 [7.87]	19.82 [50.34]	API RP-43
	EXP-3319-302	DP	RDX	19.0	3-3/8 [86]	6 [20] 60°	4-1/2 [114]	0.41 [10.41]	22.04 [55.98]	API RP-43
	EXP-3323-401T	DP	HMX	22.7	3-1/8 [79]	6 [20] 60°	4-1/2 [114]	0.43 [10.92]	23.54 [59.80]	API RP-43
	EXP-3323-302	DP	RDX	22.7	3-3/8 [86]	6 [20] 60°	4-1/2 [114]	0.44 [11.18]	21.25 [53.98]	API RP-43
	EXP-3323-461T	DP	HMX	22.7	3-3/8 [86]	6 [20] 60°	4-1/2 [114]	0.36 [9.14]	35.63 [90.50]	API RP-43
	EXP-3319-431	GH	HMX	19.0	3-1/8 [79]	6 [20] 60°	4-1/2 [114]	0.55 [13.97]	29.18 [74.12]	API RP 19B
	EXP-3321-431	GH	HMX	21.0	3-1/8 [79]	6 [20] 60°	4-1/2 [114]	0.56 [14.22]	29.23 [74.24]	API RP 19B
4	EXP-3323-431	GH	HMX	22.7	3-3/8 [86]	6 [20] 60°	4-1/2 [114]	0.59 [14.99]	29.42 [74.73]	API RP 19B
	EXP-3325-331	GH	RDX	25.0	3-3/8 [86]	6 [20] 60°	4-1/2 [114]	0.57 [14.48]	29.81 [75.72]	API RP-43
	FLO-3323-310B	BH	RDX	22.7	3-3/8 [86]	6 [20] 60°	4-1/2 [114]	0.70 [17.78]	6.18 [15.70]	API RP-43
	EXP-3321-421T	SDP	HMX	21.0	3-1/8 [79]	6 [20] 60°	4-1/2 [114]	0.42 [10.67]	44.19 [112.24]	API RP 19B
	EXP-3323-423T	SDP	HMX	22.7	3-3/8 [86]	6 [20] 60°	4-1/2 [114]	0.45 [11.43]	42.21 [107.21]	API RP 19B
	EXP-3326-421T	SDP	HMX	26.0	3-3/8 [86]	6 [20] 60°	4-1/2 [114]	0.41 [10.41]	50.05 [127.13]	API RP 19B
	EXP-4039-423T	SDP	HMX	38.5	4 [102]	4 [13] 90°	5-1/2 [140]	0.44 [11.18]	62.81 [159.54]	API RP 19B
	EXP-4521-423T	SDP	HMX	21.0	4-1/2 [114]	12 [39] 135/45°	7 [178]	0.37 [9.40]	35.97 [91.36]	API RP 19B
	EXP-3319-302	DP	RDX	19.0	3-3/8 [86]	6 [20] 60°	4-1/2 [114]	0.41 [10.41]	22.04 [55.98]	API RP-43
	EXP-3323-302	DP	RDX	22.7	3-3/8 [86]	6 [20] 60°	4-1/2 [114]	0.44 [11.18]	21.25 [53.98]	API RP-43
	EXP-3323-461T	DP	HMX	22.7	3-3/8 [86]	6 [20] 60°	4-1/2 [114]	0.36 [9.14]	35.63 [90.50]	API RP-43
	EXP-3319-331	GH	RDX	19.0	3-1/8 [79]	6 [20] 60°	4-1/2 [114]	0.55 [13.97]	29.18 [74.12]	API RP 19B
EXP-3319-431	GH	HMX	19.0	3-1/8 [79]	6 [20] 60°	4-1/2 [114]	0.55 [13.97]	29.18 [74.12]	API RP 19B	
EXP-3323-431	GH	HMX	22.7	3-3/8 [86]	6 [20] 60°	4-1/2 [114]	0.59 [14.99]	29.42 [74.73]	API RP 19B	
EXP-3325-331	GH	RDX	25.0	3-3/8 [86]	6 [20] 60°	5-1/2 [140]	0.56 [14.22]	35.61 [90.45]	API RP-43	
EXP-4521-431	GH	HMX	21.0	4-1/2 [114]	12 [39] 135/45°	7 [178]	0.46 [11.68]	22.02 [55.93]	API RP 19B	
FLO-4521-310B	BH	RDX	21.0	4-1/2 [114]	12 [39] 135/45°	7 [178]	0.67 [17.02]	5.49 [13.94]	API RP-43	

Expendable Gun Systems (EXP) Cont.

Shaped Charge Information					Shaped Charge Performance					
Gun OD (in)	Compatible Charge Part No.	Type	Exp. Type	Exp. Weight (g)	Tested Gun OD (in) [mm]	Shot Density (spf)[spm] Phasing	Casing OD (in) [mm]	Entry Hole (in) [mm]	Penetration (in) [cm]	Data Type
4-1/2	EXP-3326-421T	SDP	HMX	26.0	3-3/8 [86]	6 [20] 60°	4-1/2 [114]	0.41 [10.41]	50.05 [127.13]	API RP 19B
	EXP-4039-423T	SDP	HMX	38.5	4 [102]	4 [13] 90°	5-1/2 [140]	0.44 [11.18]	62.81 [159.54]	API RP 19B
	EXP-4539-425T	SDP	HMX	38.5	4-1/2 [114]	5 [16] 60°	7 [178]	0.46 [11.68]	55.70 [141.48]	API RP 19B
	EXP-4045-421T	SDP	HMX	45.0	4-1/2 [114]	5 [16] 90°	7 [178]	0.38 [9.65]	59.51 [151.16]	API RP 19B
	EXP-4521-423T	SDP	HMX	21.0	4-1/2 [114]	12 [39] 135/45°	7 [178]	0.37 [9.40]	35.97 [91.36]	API RP 19B
	EXP-3325-331	GH	RDX	25.0	4 [102]	6 [20] 60°	5-1/2 [140]	0.56 [14.22]	35.61 [90.45]	API RP-43
	EXP-4521-431	GH	HMX	21.0	4-1/2 [114]	12 [39] 135/45°	7 [178]	0.46 [11.68]	22.02 [55.93]	API RP 19B
4-5/8	FLO-4521-310B	BH	RDX	21.0	4-1/2 [114]	12 [39] 135/45°	7 [178]	0.67 [17.02]	5.49 [13.94]	API RP-43
	EXP-3326-421T	SDP	HMX	26.0	3-3/8 [86]	6 [20] 60°	4-1/2 [114]	0.41 [10.41]	50.05 [127.13]	API RP 19B
	EXP-4039-423T	SDP	HMX	38.5	4 [102]	4 [13] 90°	5-1/2 [140]	0.44 [11.18]	62.81 [159.54]	API RP 19B
	EXP-4539-425T	SDP	HMX	38.5	4-1/2 [114]	5 [16] 60°	7 [178]	0.46 [11.68]	55.70 [141.48]	API RP 19B
	EXP-4045-421T	SDP	HMX	45.0	4-1/2 [114]	5 [16] 90°	7 [178]	0.38 [9.65]	59.51 [151.16]	API RP 19B
	EXP-4521-423T	SDP	HMX	21.0	4-1/2 [114]	12 [39] 135/45°	7 [178]	0.37 [9.40]	35.97 [91.36]	API RP 19B
	EXP-3325-331	GH	RDX	25.0	4 [102]	6 [20] 60°	5-1/2 [140]	0.56 [14.22]	35.61 [90.45]	API RP-43
7	EXP-4521-431	GH	HMX	21.0	4-1/2 [114]	12 [39] 135/45°	7 [178]	0.46 [11.68]	22.02 [55.93]	API RP 19B
	FLO-4521-310B	BH	RDX	21.0	4-1/2 [114]	12 [39] 135/45°	7 [178]	0.67 [17.02]	5.49 [13.94]	API RP-43
	FLO-5028-310B	BH	RDX	28.0	5 [127]	12 [39] 135/45°	7 [178]	0.80 [20.32]	8.22 [20.88]	API RP-43
	EXP-4039-423T	SDP	HMX	38.5	7 [178]	12 [39] 135/45°	9-5/8 [245]	0.40 [10.16]	49.60 [125.98]	API RP 19B
7	EXP-7039-331	GH	RDX	38.5	7 [178]	12 [39] 135/45°	9-5/8 [245]	0.75 [19.05]	28.54 [72.49]	API RP-43
	FLO-7039-312CF	BH	RDX	38.8	7 [178]	12 [39] 135/45°	9-5/8 [245]	1.10 [27.94]	10.37 [26.34]	API RP 19B
	FLO-7045-312CF	BH	RDX	45.0	7 [178]	18 [55] 140/20°	9-5/8 [245]	1.20 [30.48]	8.75 [22.23]	API RP 19B

Recomplete Shaped Charges

Shaped Charge Information					Charge Performance								
Gun O.D. (in) [mm]	Charge Part No.	Charge Type	Wt. (g)	Tested Casing	3.5" Liner, 9.2# P110			Casing			Limiting EH (Combined Liner and Casing)		
					EH AVG (in)[mm]	EH RANGE (in)[mm]	C.V.	EH AVG (in)[mm]	EH RANGE (in)[mm]	C.V.	EH AVG (in)[mm]	EH RANGE (in)[mm]	C.V.
2-1/2 [64]	RTG-2512-372	CH	12	4.5" 13.5# P110	0.27 [6.9]	0.23-0.32 [5.8-8.1]	11.3%	0.23 [5.8]	0.21-0.26 [5.3-6.6]	9.0%	0.23 [5.8]	0.21-0.26 [5.3-6.6]	5.9%
				5.5" 20.0# P110	0.29 [7.4]	0.25-0.32 [6.4-8.1]	7.2%	0.23 [5.8]	0.20-0.26 [5.1-6.6]	7.0%	0.23 [5.8]	0.20-0.26 [5.1-6.6]	7.0%
				5.5" 23.0# P110	0.29 [7.4]	0.25-0.34 [6.4-8.6]	9.1%	0.23 [5.8]	0.21-0.26 [5.3-6.6]	5.4%	0.23 [5.8]	0.21-0.25 [5.3-6.4]	4.7%
	RTG-2512-371T	CH	12	4.5" 13.5# P110	0.30 [7.6]	0.28-0.33 [7.1-8.4]	6.7%	0.29 [7.4]	0.21-0.35 [5.3-8.9]	15.7%	0.27 [6.9]	0.21-0.33 [5.3-8.4]	12.1%
				5.5" 23.0# P110	0.31 [7.9]	0.29-0.33 [7.4-8.4]	4.5%	0.24 [6.1]	0.17-0.33 [4.3-8.4]	27.8%	0.24 [6.1]	0.17-0.31 [4.3-7.9]	25.1%
				4.5" 13.5# P110	0.38 [9.65]	0.32-0.43 [8.1-10.9]	7.8%	0.30 [7.6]	0.25-0.32 [6.4-8.1]	6.5%	0.30 [7.6]	0.25-0.32 [6.4-8.1]	6.5%
	RTG-2512-373	CH	12	5.5" 20.0# P110	0.38 [9.65]	0.34-0.41 [8.6-10.4]	7.1%	0.29 [7.4]	0.26-0.33 [6.6-8.4]	6.5%	0.29 [7.4]	0.26-0.33 [6.6-8.4]	6.5%
				5.5" 23.0# P110	0.38 [9.65]	0.37-0.41 [9.4-10.4]	3.7%	0.30 [7.6]	0.25-0.36 [6.4-9.1]	11.2%	0.30 [7.6]	0.25-0.36 [6.4-9.1]	11.2%
	FLO-2511-310B	BH	11	5.5" 23.0# P110	0.44 [11.2]	0.38-0.48 [9.7-12.2]	7.5%	0.38 [9.7]	0.22-0.55 [5.6-14.0]	28.8%	0.35 [8.9]	0.22-0.44 [5.6-11.2]	21.7%
2-3/4 [70]	EXP-2818-371	CH	18	5.5" 20.0# P110	4.0" Liner, 11.6# P110			Casing			Limiting EH (Combined Liner and Casing)		
					EH AVG (in)[mm]	EH RANGE (in)[mm]	C.V.	EH AVG (in)[mm]	EH RANGE (in)[mm]	C.V.	EH AVG (in)[mm]	EH RANGE (in)[mm]	C.V.
					0.43 [10.9]	0.34-0.48 [8.6-12.2]	10.8%	0.35 [8.9]	0.28-0.39 [7.1-9.9]	9.0%	0.35 [8.9]	0.28-0.39 [7.1-9.9]	9.0%

Ported Casing (PPG)

Shaped Charge Information					Shaped Charge Performance					
Gun OD (in)	Compatible Charge Part Number	Type	Explosive Type	Exp. Weight (g)	Tested Gun OD (in) [mm]	Shot Density (spf) [spm] Phasing	Casing OD (in) [mm]	Entry Hole (in) [mm]	Penetration (in) [cm]	Data Type
3-1/8 & 3-3/8	PPG-3112-321T	SDP	RDX	12.0	3-1/8 [79]	4 [13] 120°	4-1/2 [114]	0.34 [8.67]	22.40 [56.90]	API RP-43
	PPG-3111-301	DP	RDX	11.0	3-1/8 [79]	4 [13] 120°	4-1/2 [114]	0.36 [9.14]	16.82 [42.72]	API RP-43
	PPG-3111-331	GH	RDX	11.0	3-1/8 [79]	4 [13] 120°	4-1/2 [114]	0.41 [10.41]	19.15 [48.64]	API RP-43
	PPG-3111-311	BH	RDX	11.0	3-1/8 [79]	4 [13] 120°	4-1/2 [114]	0.54 [13.72]	15.71 [39.90]	API RP-43
4	PPG-4019-321T	SDP	RDX	19.0	4 [102]	4 [13] 120°	5-1/2 [140]	0.40 [10.16]	23.74 [60.30]	API RP-43
	PPG-4023-321T	SDP	RDX	22.7	4 [102]	4 [13] 120°	5-1/2 [140]	0.40 [10.16]	33.68 [85.55]	API RP-43
	PPG-4019-301	DP	RDX	19.0	4 [102]	4 [13] 120°	5-1/2 [140]	0.46 [11.68]	24.35 [61.85]	API RP-43
	PPG-4022-301	DP	RDX	22.0	4 [102]	4 [13] 90°	5-1/2 [140]	0.47 [11.94]	21.42 [54.41]	API RP-43

Economical Expendable (EEG) Gun System Shaped Charges

Shaped Charge Information					Shaped Charge Performance					
Gun OD (in)	Compatible Charge Part Number	Type	Explosive Type	Exp. Weight (g)	Tested Gun OD (in) [mm]	Shot Density (spf) [spm] Phasing	Casing OD (in) [mm]	Entry Hole (in) [mm]	Penetration (in) [cm]	Data Type
3-1/8	EXP-3321-421T	SDP	HMX	21.0	3-1/8 [79]	4 [13] 60°	4-1/2 [114]	0.43 [10.92]	42.13 [107.01]	API RP 19B
	RTG-2512-421T	SDP	HMX	12.0	2-3/4 [70]	6 [20] 60°	4-1/2 [114]	0.36 [9.14]	31.90 [81.03]	API RP 19B
	EXP-3319-302	DP	RDX	19.0	3-3/8 [86]	6 [20] 60°	4-1/2 [114]	0.41 [10.41]	22.04 [55.98]	API RP-43
	EXP-3319-431	GH	HMX	19.0	3-1/8 [79]	6 [20] 60°	4-1/2 [114]	0.55 [13.97]	29.18 [74.12]	API RP 19B
	RTG-2512-431	GH	HMX	12.0	2-1/2 [64]	6 [20] 60°	3-1/2 [89]	0.45 [11.43]	20.31 [51.59]	API RP 19B
4	EXP-3321-421T	SDP	HMX	21.0	3-1/8 [79]	4 [13] 60°	4-1/2 [114]	0.43 [10.92]	42.13 [107.01]	API RP 19B
	EXP-3323-423T	SDP	HMX	22.7	3-3/8 [86]	6 [20] 60°	4-1/2 [114]	0.45 [11.18]	42.21 [107.21]	API RP 19B
	EXP-3323-302	DP	RDX	22.0	3-3/8 [86]	6 [20] 60°	4-1/2 [114]	0.43 [10.92]	19.56 [50.00]	API RP-43
	EXP-3323-461T	DP	RDX	22.7	3-3/8 [86]	6 [20] 60°	4-1/2 [114]	0.36 [9.14]	35.63 [90.50]	API RP-43
	EXP-3319-431	GH	HMX	19.0	3-1/8 [79]	6 [20] 60°	4-1/2 [114]	0.55 [13.97]	29.18 [74.12]	API RP 19B
	EXP-3323-431	GH	HMX	22.7	3-3/8 [86]	6 [20] 60°	4-1/2 [114]	0.59 [14.99]	29.42 [74.73]	API RP 19B
	EXP-3325-331	GH	RDX	25.0	4 [102]	6 [20] 60°	5-1/2 [140]	0.56 [14.22]	35.61 [90.45]	API RP-43

KnockOut® Puncher & Circulation Shaped Charges

Shaped Charge Information				Shaped Charge Performance			
Gun OD (in)[mm]	Charge Part Number	Explosive Weight (g)	Shot Density (spf)[spm]	Phasing	Exit Hole (in)[mm]	L-80 Wall Thickness (in)[mm]	Impact to Secondary String with 1/4" Water Clearance (in)[mm]
1-3/8 [35]	CIR-1302-4T251	2	4 [13]	0°	0.30 [7.62]	0.25 [6.35]	0.01 [0.25]
	CIR-1302-4T381	2	4 [13]	0°	0.25 [6.35]	0.38 [9.53]	0.01 [0.25]
1-9/16 [40]	CIR-1603-4T251	3.0	4 [13], 6 [20]	0°	0.43 [10.92]	0.25 [6.35]	0.02 [0.51]
	CIR-1603-4T381	3.5	4 [13], 6 [20]	0°	0.37 [9.40]	0.38 [9.53]	0.02 [0.51]
	CIR-1603-4C501	3.2	4 [13], 6 [20]	0°	0.33 [8.38]	0.50 [12.70]	0.04 [1.01]
	CIR-1603-4C631	3.5	4 [13], 6 [20]	0°	0.22 [5.59]	0.63 [15.88]	0.03 [0.76]
2 [51]	CIR-2107-4T251	7.0	4 [13], 6 [20]	0°	0.62 [15.75]	0.25 [6.35]	0.07 [1.78]
	CIR-2107-4T381	7.0	4 [13], 6 [20]	0°	0.61 [15.49]	0.38 [9.53]	0.04 [1.01]
	CIR-2107-4C501	7.0	4 [13], 6 [20]	0°	0.45 [11.43]	0.50 [12.70]	0.02 [0.51]
	CIR-2107-4C631	7.0	4 [13], 6 [20]	0°	0.35 [8.89]	0.63 [15.88]	0.05 [1.27]

Hunting's Shaped Charge Part Numbering System

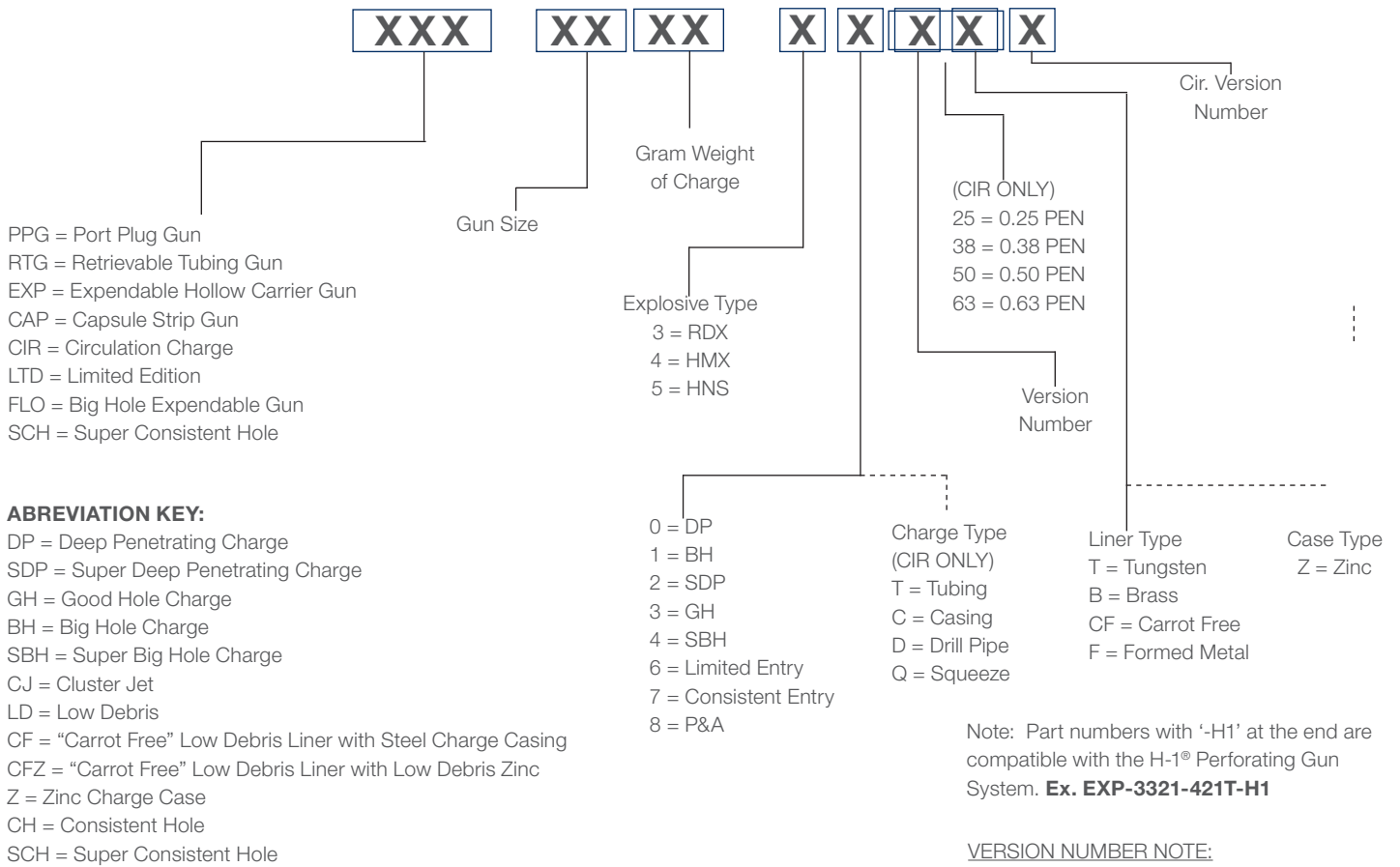

Unique Identification Numbers



- Meets EU requirement for traceability
- Meets FEEM requirements for track-and-trace guidance
- Provides full traceability of materials used
- Ties directly into Hunting's quality system
- Identification number is unique to each shaped charge
- Enables quick identification of explosive type and gram weight

Products and Services

- ▶ Hunting's mission is to innovate and manufacture quality oil/gas extraction equipment and distribute it across our global supply chain.
- ▶ Hunting's energetics division produces the greatest number of shaped charges in the world.
- ▶ Hunting's instrument division produces the most widely used addressable switch in the world.

Proprietary Technology

Hunting develops innovative technology that improves the way oil and gas are extracted, with a full range of applications below the wellhead including mud motors, premium connections, well perforating, logging and intervention tools.

Geographic Footprint

Manufacturing and distribution locations are strategically located in the key energy producing regions of the world.

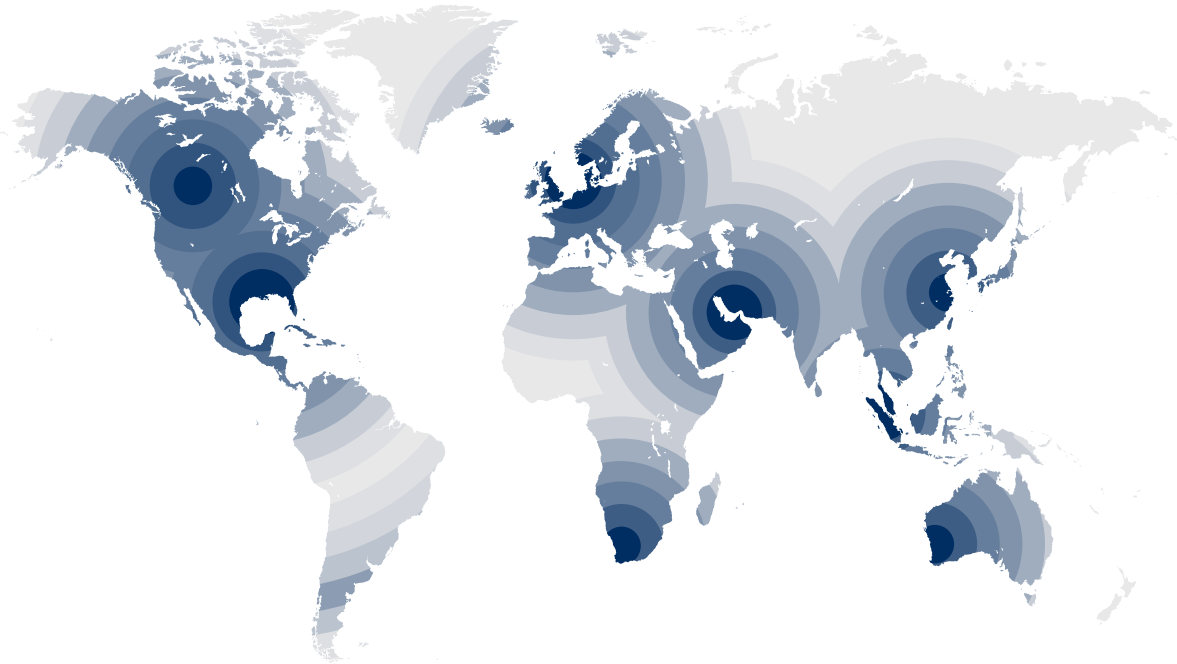

Global Business Units

OCTG and Connection Technology
Drilling Tools

Perforating Systems & Instrumentation
Well Intervention

Advanced Manufacturing
Subsea Technologies

Further Information

Web

www.hunting-intl.com

Email

sales.titan@hunting-intl.com
support.titan@hunting-intl.com

Global Headquarters

Hunting Energy Services Inc.
16825 Northchase Drive, Suite 600
Houston, Texas 77060-3236
USA

T. +1 281 442 7382



'Excellence in **Energy Services** for over 100 years'