



SEAL-LOCK HT ANCILLARY SPECIFICATIONS

| SECTION | V | |
|-------------------|------------|-----------------|
| Approved Engineer | RJH | 04/20/96 |
| Approved Mgr Engr | DR | 04/20/96 |
| Approved VP QA | HDG | 04/20/96 |
| REVISION | 001 | 04/20/96 |

| | |
|-----------------|---|
| SUBJECT: | MAKE-UP POSITION USING BARRETTES |
|-----------------|---|

1.0 DEFINITION

1.1 A barrette pair is a longitudinal section of a power tight connection that has been separated into a pin barrette and a box barrette.

2.0 PURPOSE

2.1 The barrette pair is used to determine the proper make-up position or the pin to box relationship when making up a connection power tight.

3.0 EQUIPMENT

3.1 The following list of equipment is required to apply the make-up marks:

- 3.1.1 A pin and box barrette pair (with matching serial numbers) for the appropriate connection being made-up.
- 3.1.2 A white or yellow paint marker.

4.0 PROCEDURE

- 4.1 Assure that both the pin and box connectors to be made-up are cleaned of all thread lubricant and other material.
- 4.2 Place the pin barrette inside the coupling, engage the barrette and coupling threads, and rotate the barrette clock wise until the coupling face and barrette shoulder firmly contact.
- 4.3 Using the paint marker, mark a longitudinal line on the coupling chamfer and/or coupling OD to correspond with the line indicated on the barrette.

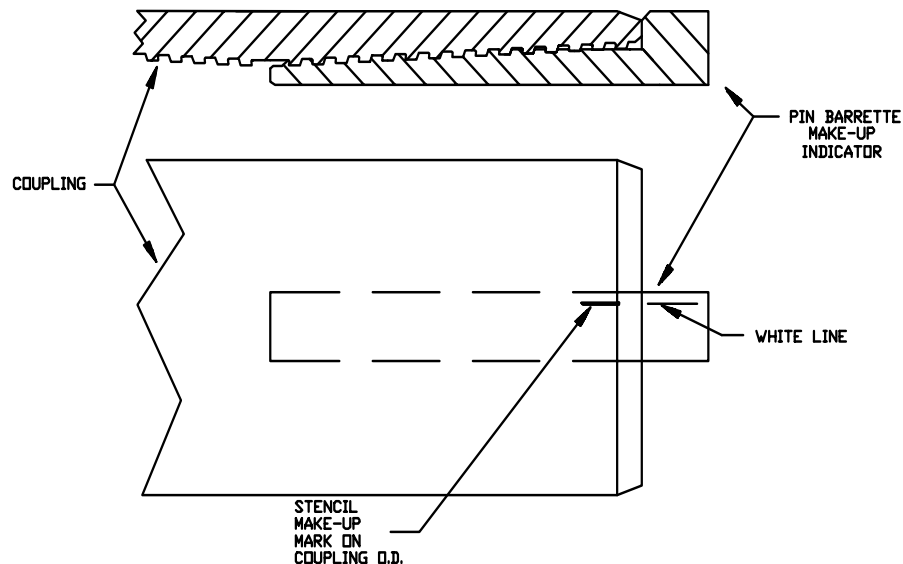



SEAL-LOCK HT ANCILLARY SPECIFICATIONS

| SECTION | V | |
|-------------------|-----|----------|
| Approved Engineer | RJH | 04/20/96 |
| Approved Mgr Engr | DR | 04/20/96 |
| Approved VP QA | HDG | 04/20/96 |
| REVISION | 001 | 04/20/96 |

SUBJECT: MAKE-UP POSITION USING BARRETTES

- 4.4 Remove the barrette from the coupling by turning counterclockwise until the shoulders and threads disengage.
- 4.5 Place the box barrette on the pin connector, engage the box barrette and pin connector threads, and rotate clockwise until the pin face and the box barrette shoulder firmly contact.
- 4.6 Using the paint marker, mark a circumferential line on the pipe OD that corresponds to the barrette/coupling face and a longitudinal line to correspond with each line indicated on the barrette.
- 4.7 Remove the barrette from the pin connector by turning counterclockwise until the shoulders and threads disengage.

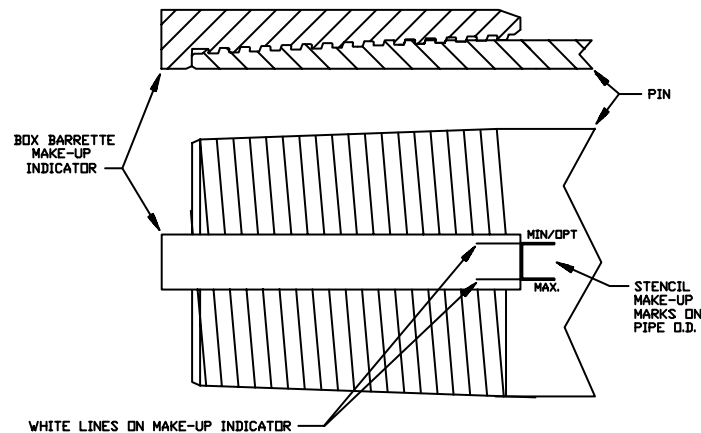

5.0 MAKE-UP INSPECTION

- 5.1 With the connection made-up per Hunting's coupling make-up or field running procedures, visually inspect to assure that the longitudinal lines on the coupling and pipe OD are roughly aligned and the coupling face is approximately in the same longitudinal place as the leading edge of the circumferential line on the pipe OD.
- 5.2 Using a ruler with at least 1/16" increments or dial calipers, measure the distance from the made-up pin face inside the coupling to the face of the open end of the coupling. The distance shall be approximately 1/2 the coupling length. Also, visually check that the pin is approximately in the center of the coupling center groove.



**SEAL-LOCK HT
ANCILLARY
SPECIFICATIONS**

| SECTION | V | |
|-------------------|------------|-----------------|
| Approved Engineer | RJH | 04/20/96 |
| Approved Mgr Engr | DR | 04/20/96 |
| Approved VP QA | HDG | 04/20/96 |
| REVISION | 001 | 04/20/96 |

SUBJECT: MAKE-UP POSITION USING BARRETTES

